



Building Automation





Contents

Automating with WAGO	4
WAGO Building Solutions	6
Integrated Building Automation	7
Universal, Compact, Economical – the WAGO I/O System	8
WAGO I/O System 750/753	10
Basic Software	12
Libraries	14
Macro for Flexible Room Automation	15
Modules for Distribution Boxes	16
flexROOM®	18
WAGO Lighting Management	20
KNX®	22
BACnet®	23
DALI-2	24
Modbus TCP/IP	26
Cybersecurity Right in the Switch	27
SMI Master	28
EnOcean® Radio Technology	28
M-Bus Master	29
MP-Bus Connection	29
Touch Panels 600	30
Additional Technologies	31

Automating with WAGO

WAGO's ELECTRICAL INTERCONNECTIONS division has undergone rapid development over the years, paving the way for more industry-leading innovations. An important milestone in the company's history was the launch of the WAGO I/O System, the world's first fieldbus-independent I/O system with fine-grained modularity, in 1995. The introduction of industrial fieldbus systems has significantly impacted automation. Modern, decentralized topologies with distributed "intelligence" have replaced traditional, centralized automation structures. Now, WAGO is meeting virtually all of the industry's needs as both the leader in spring pressure

connection technology and a pioneer in automation technology. For more than 15 years, the wide range of advanced building automation components based on the WAGO I/O System 750 has been successfully proven in practice. The system's modular design enables solutions to be easily and efficiently implemented. A wide range of controllers with open fieldbus protocols (e.g., M-Bus, BACnet®, KNX® and Modbus®) in combination with standard inputs/outputs or subsystems (e.g., DALI, SMI, EnOcean® and LonWorks®) covers the entire building automation market.



Engineering Software

The right engineering environment can save development time and money. WAGO offers the right tool for every application. WAGO's integrated e!COCKPIT engineering software supports all your development activities – from hardware configuration and programming to visualization. WAGO Solution Builder is an engineering software tailored to building automation. It gives you an integrated and efficient way to create solutions throughout the entire life cycle of your building.



Operation and Monitoring

WAGO's high-performance touch panels for demanding control and visualization tasks not only improve the operability of building technology systems, but also offer an outstanding design and advanced technology.

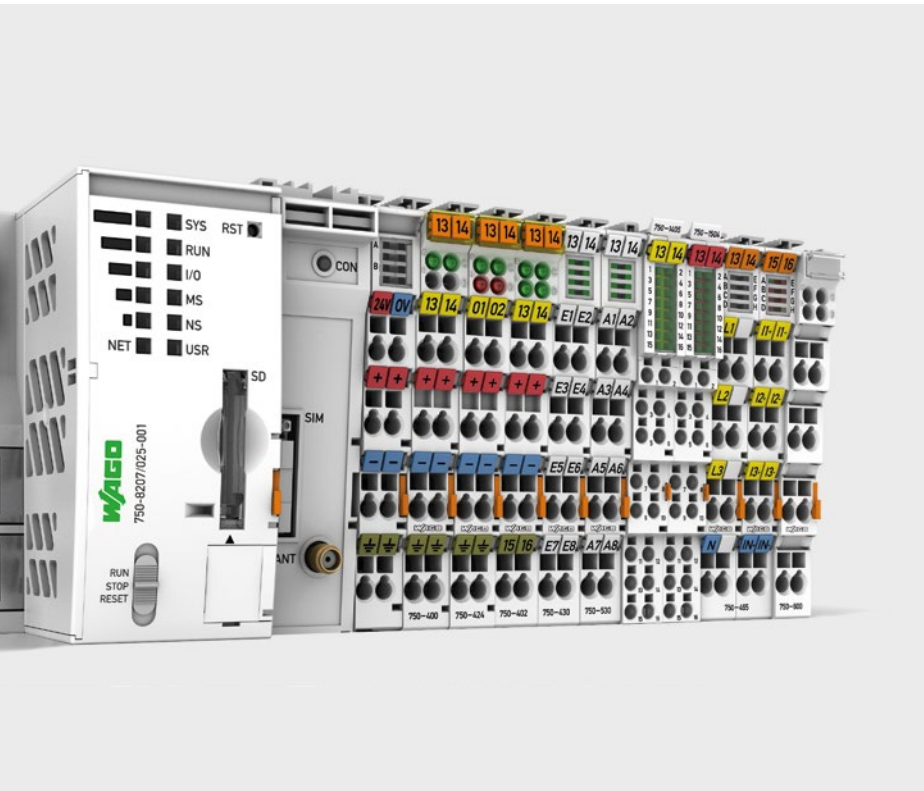

WAGO I/O System

Whether inside or outside the control cabinet: WAGO's I/O system provides automation right where you need it – even under extreme conditions. The broad portfolio enables flexible, cellar-to-ceiling solutions with conventional I/O modules, standardized industry-specific fieldbus protocols and subsystems (DALI, KNX®, DMX) for typical applications in lighting, shading, HVAC and much more. The portfolio also includes a comprehensive selection of accessories (e.g., RJ-45 plugs and RS-485 interfaces).



Controllers

WAGO's family of high-performance programmable controllers boasts a wide range of capabilities for controlling any automation task in both centralized and decentralized applications. For decentralized control tasks, the controllers can be incorporated into the most prevalent fieldbus networks. All field signals are recorded via I/O modules and

edge controllers/computers. WAGO's IEC 61131-3 programmable controllers perform several automation tasks and provide all the benefits of proven PLC technology (e.g., strength, stability, reliability and near-high constant uptime).



Industrial Switches and Wireless Technology

In building automation and industrial automation, industrial switches enable communication within industrial ETHERNET systems. These are complemented by economical industrial managed switches, which reliably transmit data traffic securely, thanks to encryption technology and authentication. They also protect against network failures, increasing system availability.

WAGO Building Solutions

For Specific Markets



Office and Administrative Buildings

Flexible use of space supported by an appropriate infrastructure is becoming increasingly important for investors. To address this need, WAGO's room automation systems can be commissioned quickly and flexibly adapted. With WAGO products, efficiency class A per DIN EN 15232 can be achieved easily and reliably.



Production Facilities and Warehouses

An adaptive lighting system is critical for safe and efficient work in production facilities and warehouses. However, it's also essential to keep lighting from becoming a major cost. WAGO's lighting management system ensures optimal lighting with low operating costs.



Retail

A smart building solution makes it possible to provide comfort and a pleasant atmosphere with low operating costs. Intelligent buildings provide a secure and comfortable environment – all while keeping costs tightly controlled. WAGO's building automation systems reliably help operators meet specific energy cost targets.

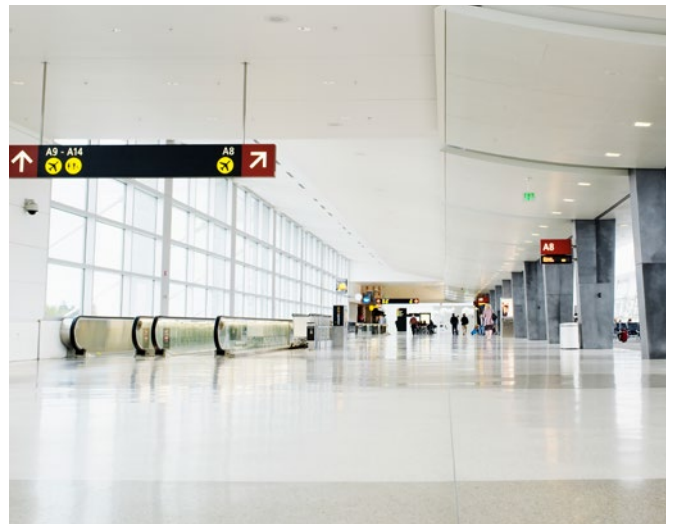

Public Infrastructure Buildings

WAGO's integrated building automation solutions meet the high operational safety and efficiency standards for public infrastructure buildings.

Integrated Building Automation – Greater Energy Efficiency



Lighting

The ideal lighting control system not only creates an atmosphere that promotes a sense of well-being, but also supports energy-efficient room and building lighting automation. WAGO's lighting control solutions skillfully create lighting scenes – from simple switching and dimming, to tailored and daylight-dependent lighting controls. Even sophisticated control tasks like “Human Centric Lighting” (HCL), as well as impressive and artistic lighting of buildings, can be easily implemented using WAGO products. The “WAGO Lighting Management” application solution offers quick and easy commissioning, as well as efficient building operation.

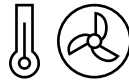

HVAC

Heating, ventilation and air-conditioning (HVAC) systems are some of building's biggest costs. Automatically regulating HVAC systems minimizes energy costs and improves a building's climate. Planning and implementing HVAC systems requires extensive knowledge from every building automation professional – from creating sophisticated control programs to visualizing energy flows. Extensive libraries with ready-made system macros from WAGO make programming considerably easier. Using these system macros contributes to standardization, significantly reducing costs.



Room Automation

Planning, implementing and operating a building must demonstrate maximum efficiency and a high degree of adaptability. Modern building technology maximizes flexibility by allowing rooms to be individually planned, managed and even repurposed at any time – no programming necessary. WAGO's state-of-the-art room automation solutions perform many tasks in a building: They optimize room temperature, position sunblinds based on the sun's arc throughout the day, regulate light intensity and switch lights off when not needed. Thus, WAGO's room automation system even fulfills the Class A requirements of EN 15232, which require combined control of lighting, sun shading devices and HVAC systems.



Energy Efficiency

Energy efficiency hinges on sensibly planning a building's technical systems. When constructing or retrofitting buildings, saving energy is an operational challenge. Investors want to see a high level of energy efficiency in their buildings. WAGO solutions achieve compliance with the European Union's energy efficiency class A. At the same time, WAGO's building automation solutions can help optimize the building's operational lifecycle costs.

Universal, Compact, Economical – the WAGO I/O System

Management

The automation stations are connected to the building management system at the management level. Standardized protocols facilitate simple data exchange.

Thanks to modern information technology, the most important information from building automation is no longer restricted to in-house building management; it's now available at any time and place. However, this requires certain technical preconditions. WAGO's PFC Controllers are equipped with cloud connectivity and transfer data to WAGO Cloud – or any other MQTT broker.

Automation

Automation stations control and regulate operational systems. ETHERNET has long since established itself as the dominant transmission medium within automation. As such, WAGO's automation stations can be easily and efficiently interlinked using open, standardized bus protocols for building automation (e.g., BACnet IP, KNX IP or Modbus/TCP). I/O modules and fieldbus interfaces permit nearly any sensor or actuator to be connected from the field.

Field

Flexible, easy-to-install media are required at the field level. This is why WAGO offers a wide variety of solutions: From products for directly connecting standard sensors and actuators via I/O modules, to a variety of fieldbus interfaces for two-wire subsystems (e.g., Modbus RTU, MP-Bus, M-Bus, BACnet MS/TP, KNX TP1 and LonWorks®), to connection with radio systems like EnOcean®.

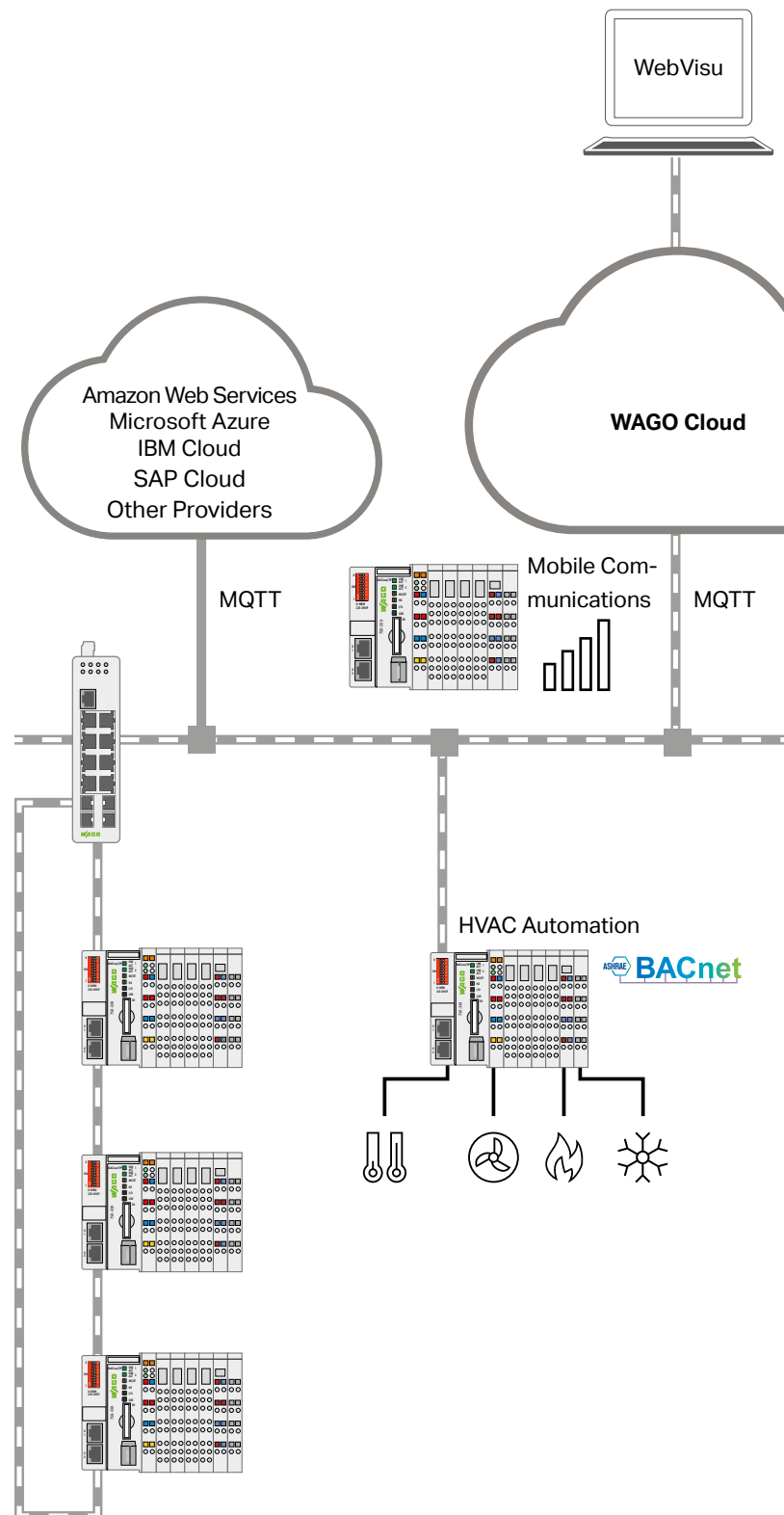

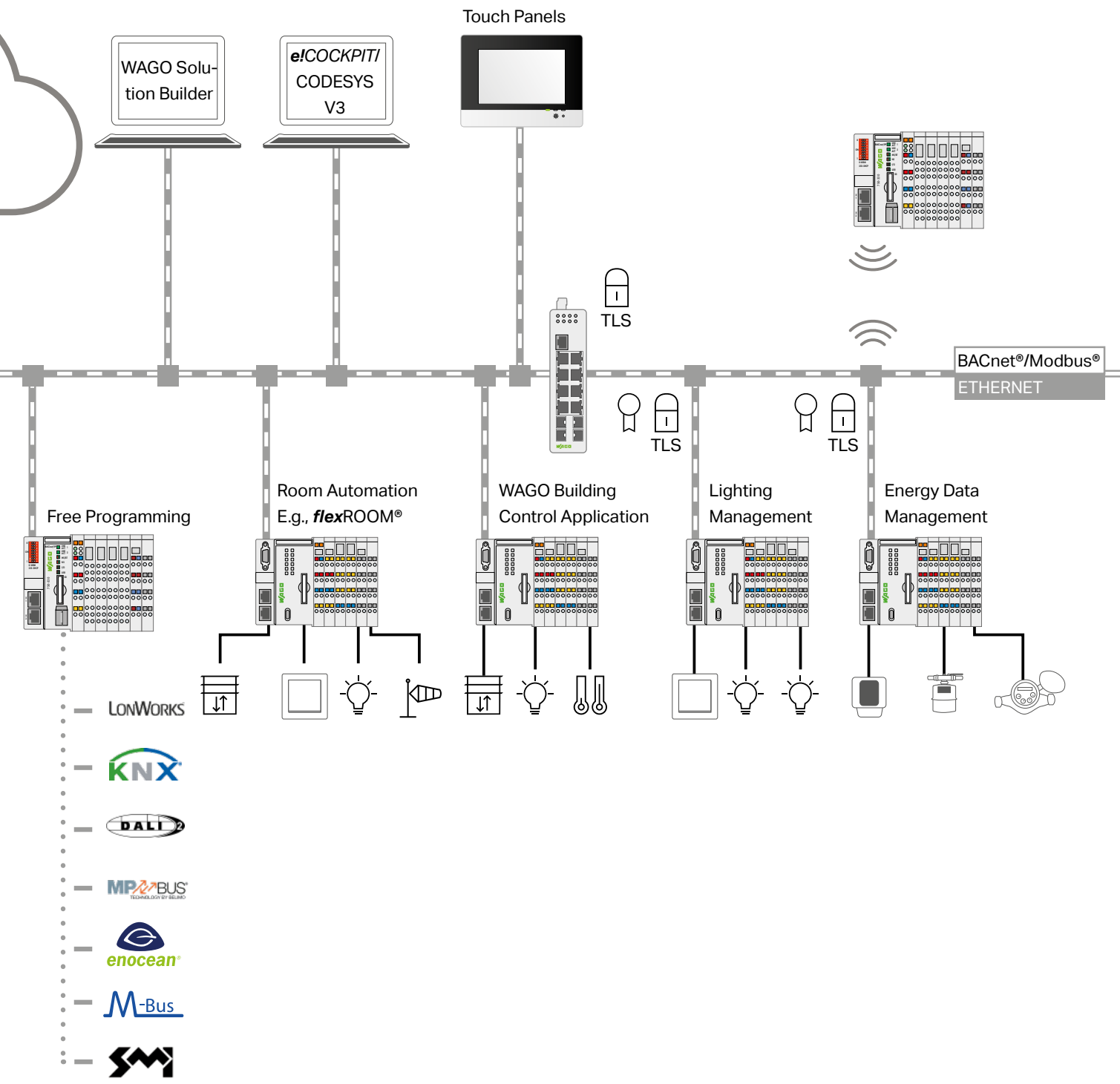



WAGO I/O System 750

Automation Stations and I/O Modules

WAGO's comprehensive range of fieldbus controllers supports established protocol standards. Dedicated controllers, e.g., for the BACnet/IP and KNX IP fieldbus systems, are ideal for building automation applications. The diverse product range of I/O modules allows integration of external systems such as lighting control (DALI), sun protection (SMI), wireless switches (EnOcean®) and many much more.

BACnet® Controller

For BACnet® communication, WAGO offers two different controllers equipped with BACnet/IP (ETHERNET) or BACnet MS/TP (RS-485) interfaces. Both controller variants support the BACnet Building Controller (B-BC) profile and are freely programmable. The controllers can be easily commissioned with WAGO's user-friendly BACnet Configurator.

KNX IP Controller

The KNX IP fieldbus controller is freely programmable and communicates via a standard 10/100 Mbit ETHERNET network. The KNX interface is commissioned using the ETS network management tool. A product database from WAGO is available for this task.

ETHERNET Controllers

WAGO provides a wide range of ETHERNET controllers in different performance classes and with various interface combinations. The ETHERNET fieldbus controllers support a wide variety of standard ETHERNET protocols for easy integration into IT environments (e.g., HTTP, BootP, DHCP, DNS, SNTP, SNMP and FTP).

PFC Controllers

Its CODESYS-based runtime environment and real-time-capable Linux® operating system make the PFC200 Controller an efficient control solution for your automation applications. The large number of variants and interfaces makes it especially flexible.

Modbus® Controllers

The Modbus® protocol is a communication protocol based on master/slave or client/server architecture. The primary purpose of the protocol is facilitating fast, reliable communication between automation and field devices.



Analog Input Modules

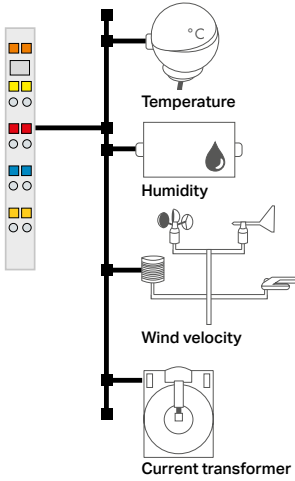

Analog Output Modules

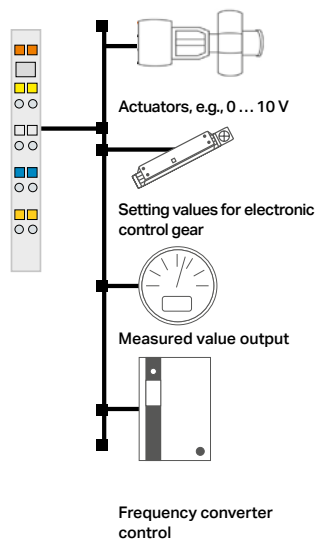

Digital Input Modules

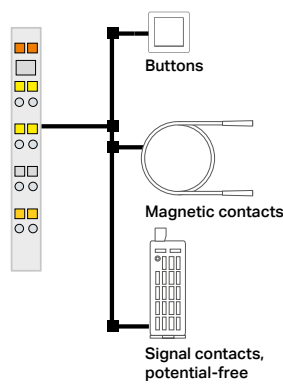

Digital Output Modules

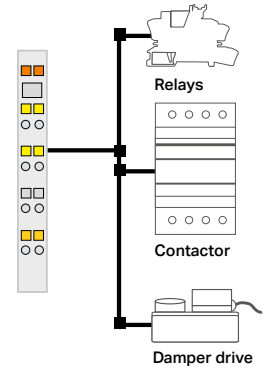

Communication Modules
RS-232 C/RS-485

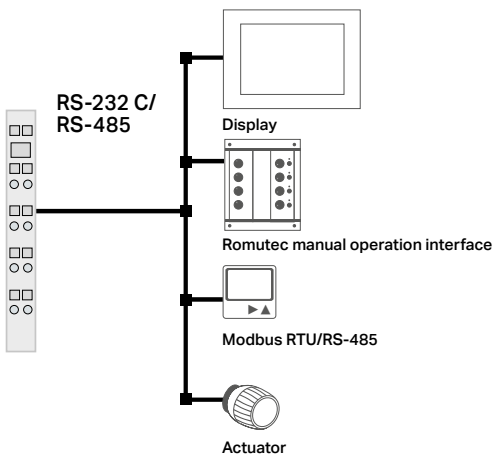

Specialty Modules

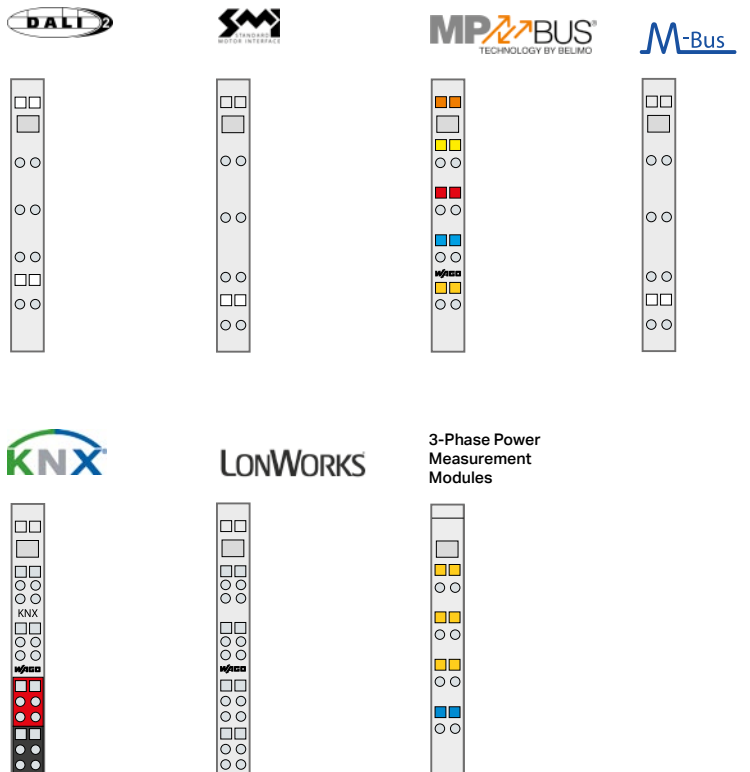

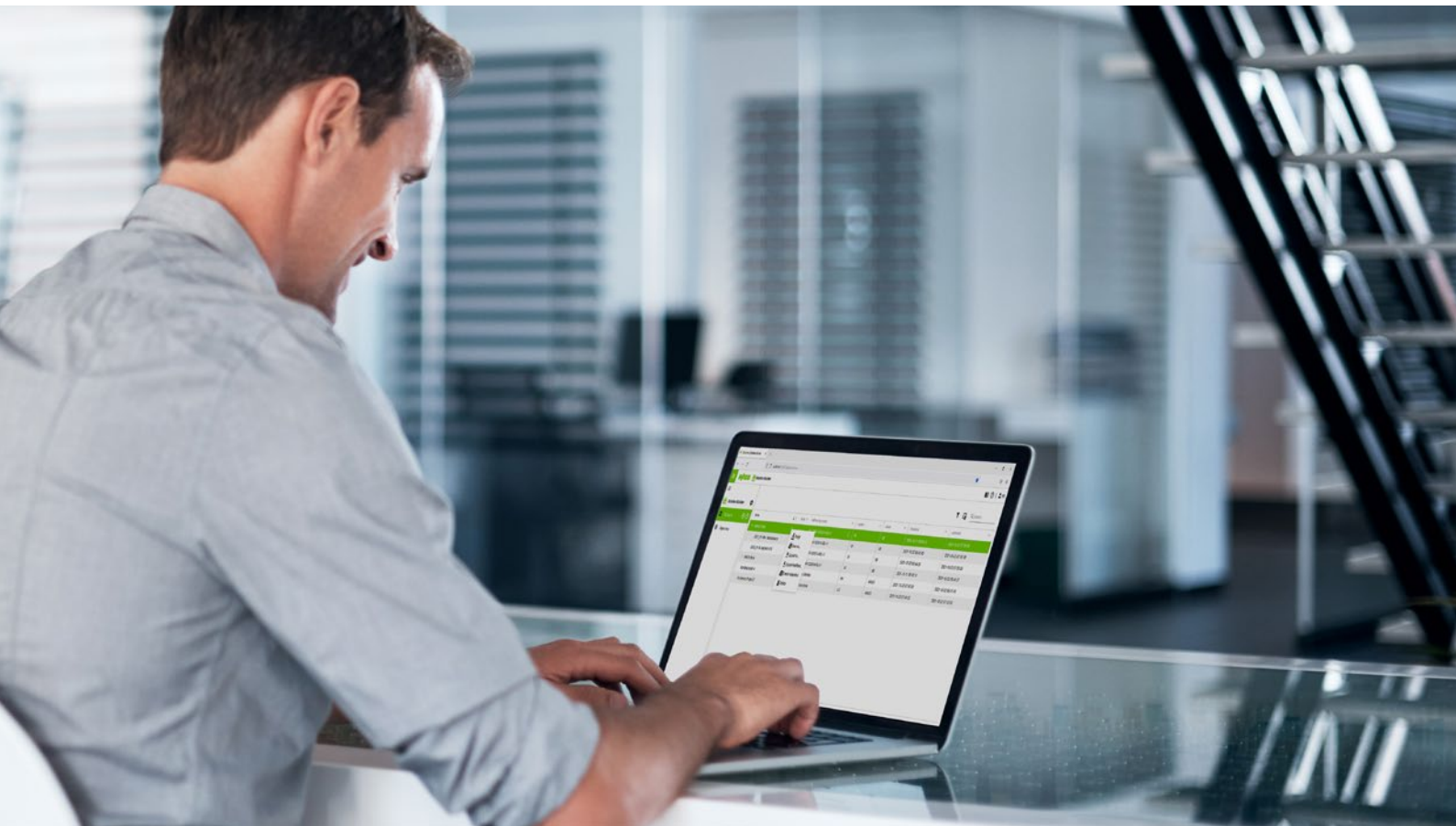

Basic Software

Programming and Configuring with WAGO

Automation projects demand shorter and shorter implementation times and more complex structures, and software represents a greater and greater portion of the overall solution. That makes automation engineering a key factor influencing the success of your project.

WAGO provides you with two proprietary software solutions for project engineering, which you can use to put systems into operation more quickly and shorten development times for automation. The PC-based **e!COCKPIT** Engineering Software is an integrated development environment that supports every task for automating machines and systems: from hardware configuration, programming, simulation and visualization to commissioning – an all-in-one software package. WAGO Solution Builder is an integrated, efficient software solution specifically for building automation. It allows you to take a holistic approach to project engineering – throughout the entire lifecycle of your building. Here the workflow is optimized to keep the processes of creating the entire project in the office (offline) and commissioning it on site (online) separate.

The Benefits of e!COCKPIT for You:

- Integration of new devices like touch panels and second-generation PFCs
- A smart design
- Graphical network configuration
- Extensive libraries with ready-made system macros

The Benefits of WAGO Solution Builder for You:

- A clearly organized representation of the system on a Web interface
- An efficient workflow to save engineering time
- Intelligent bulk processing of data and devices helps prevent errors
- Simple, comprehensive project documentation with one mouse click



Configuring



Programming



Visualizing



Diagnosing

Communication in the BACnet® and Modbus® Network

WAGO offers software tools specifically engineered for select technologies, applications and products. Among these are WAGO's BACnet and Modbus® Configurators, which allow devices connected to a specific network to be easily and efficiently addressed and parameterized.

The Modbus® Configurator is integrated into e!COCKPIT; the BACnet® Configurator is an

add-on application for the e!COCKPIT programming environment. Both configurators are used directly in the programming environment for quickly integrating the WAGO controllers into the corresponding networks.

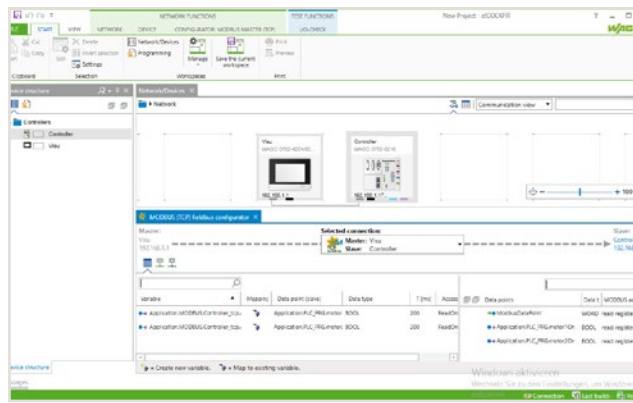
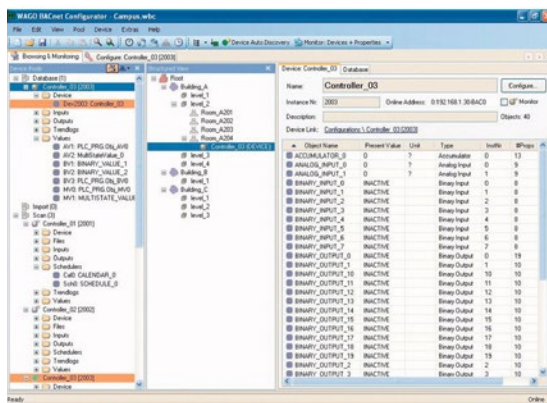

WAGO-I/O-CHECK in e!COCKPIT

As a component of e!COCKPIT, WAGO-I/O-CHECK is an easy-to-use application for operating and displaying a WAGO I/O System 750's controller without the node being connected to a fieldbus system. The software reads the configuration from the node and displays it graphically on the screen. This graphic can be printed together with a configuration list as documentation. With WAGO-I/O-CHECK, it is possible to display and specify the process data of the I/O modules. The field wiring, including all sensors and actuators, can thus be checked before commissioning.

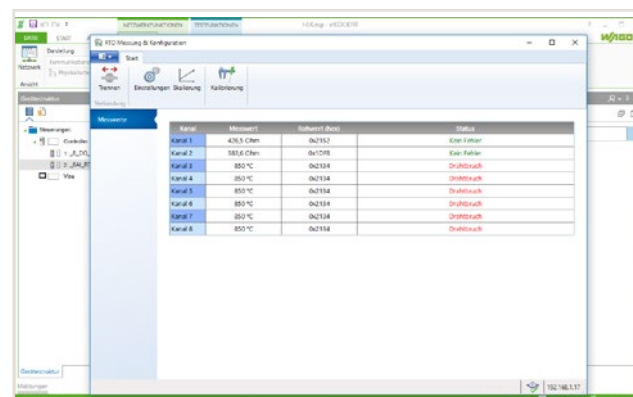
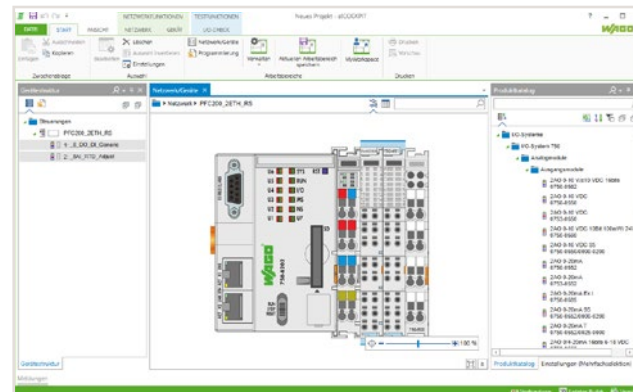

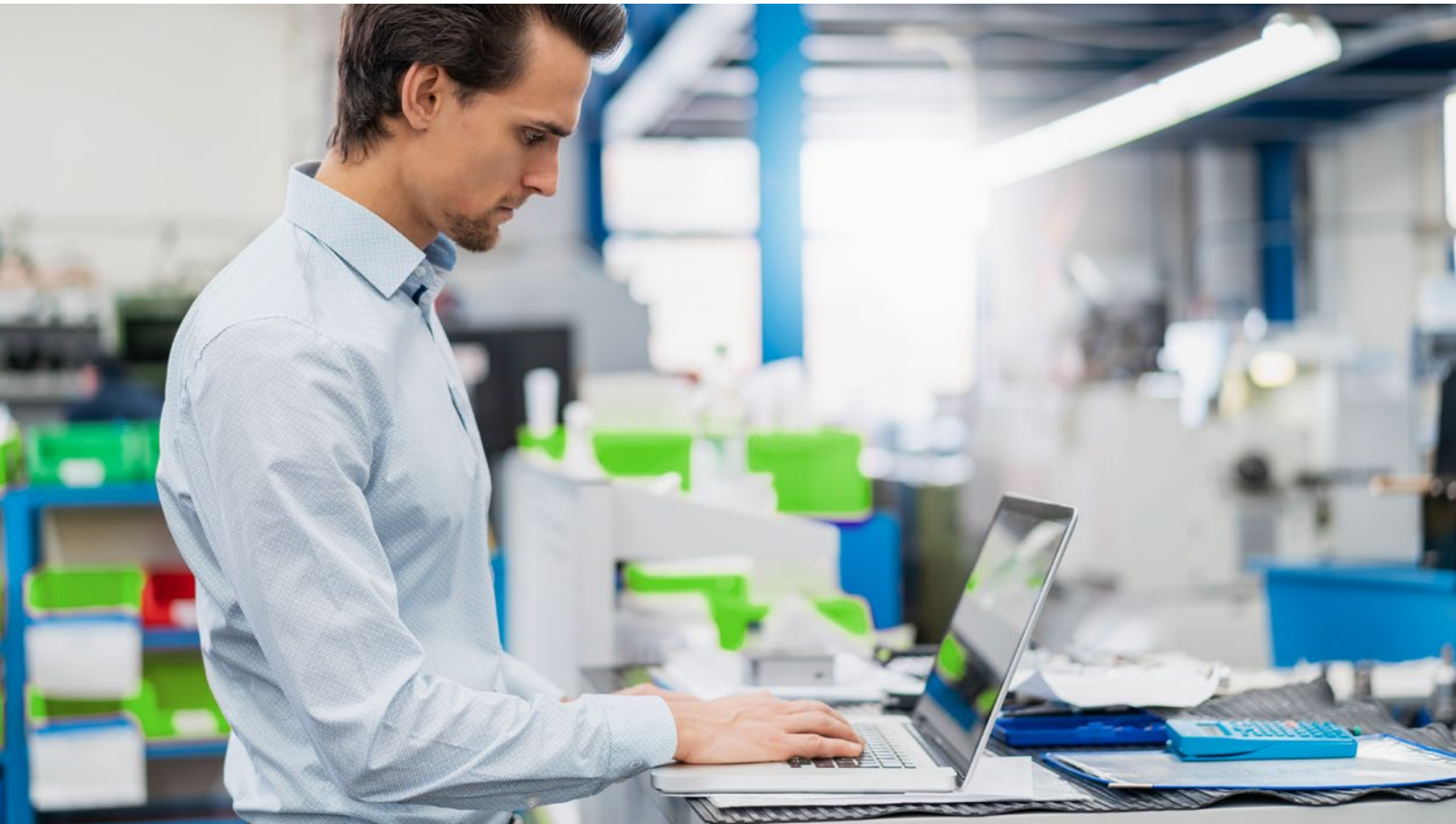

Libraries

Building Automation

To simplify programming, WAGO has a multitude of pre-configured functions available for free: from simple room applications like lighting, dimming and anti-glare control, to HVAC modules, system macros and communication applications. The latter offer interfaces to KNX®,

DALI, EnOcean® and MP-Bus and allows emailing and texting. The libraries can be used directly to efficiently create customer applications.

Libraries for the following applications are available:

Room Automation

- Lighting
- Sun protection
- Room temperature control

System Automation (HVAC)

- Error message monitoring
- Frost protection monitoring
- Heat recovery
- Room/air intake temperature cascade control
- Heating circuit control
- Boiler sequence control

Communication

- KNX®
- EnOcean®
- DALI
- DMX
- SMI
- MP-Bus
- M-Bus
- SMS/email
- Cloud (e.g., MQTT)
- BACnet®

Application Notes

For complex building automation challenges, examples and documents are available that describe applications in their entirety.

Modules for Distribution Boxes

The products and solutions outlined in this brochure provide a solid foundation for building automation. However, additional peripheral systems, control modules and components are required for complete automation solutions.

WAGO not only provides a wide range of products, but can also furnish tailor-made solutions consisting of fully equipped system distribution boxes. Users benefit not only from shorter assembly times and error-free installation, but also from easier commissioning.

Key Components at a Glance:

- **Power Supplies**
24 V power supply for WAGO Controllers
- **Network Infrastructure Components**
From a simple switch to configurable communication capabilities with a fiber optic connection
- **Customizable ETHERNET**
User-configurable ETHERNET RJ-45 connectors
- **Interface Modules**
For RJ-45 patch cables and universal connections, such as a 9-pole Sub-D RS-232 connection

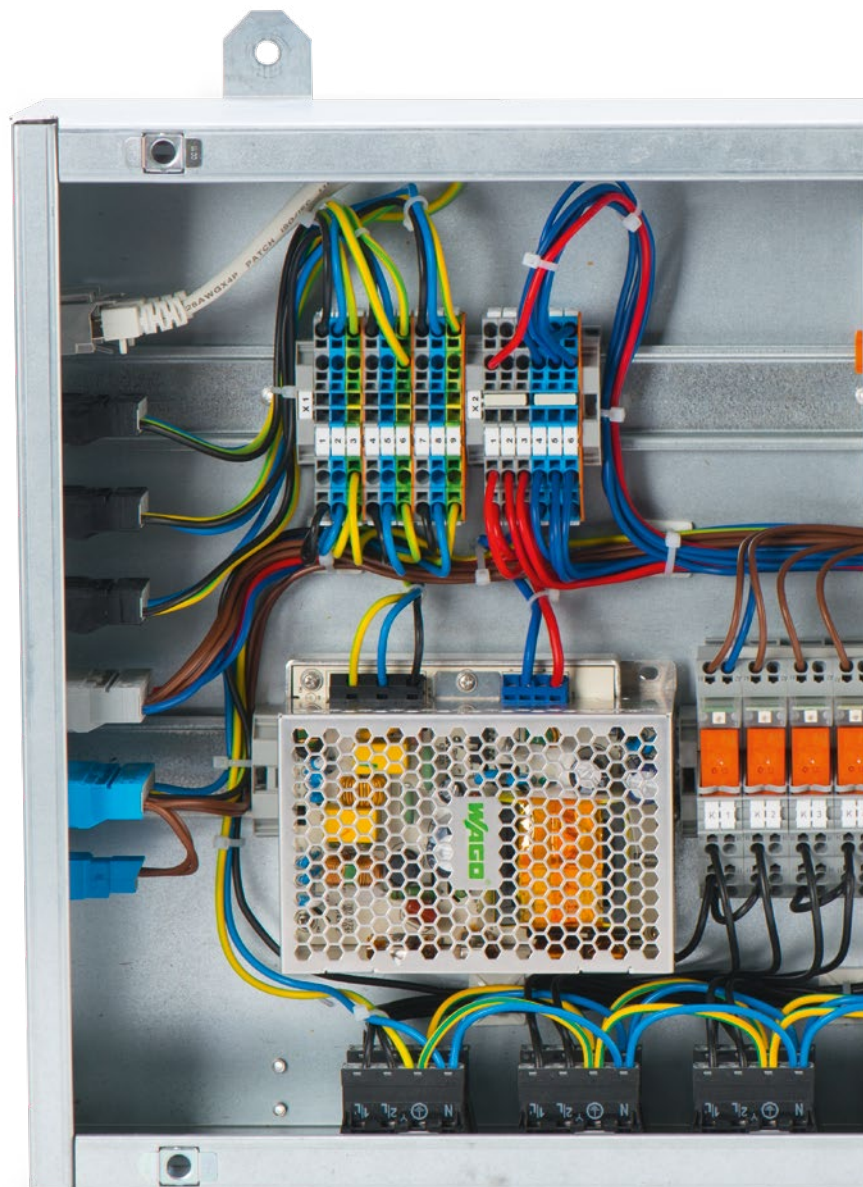

- **Relays**

To control loads, such as lights and shutter drives much more.

- **WINSTA® Pluggable Connectors**

Innovative connectors from the WAGO WINSTA® line for pre-assembled components ensure fast, safe on-site installation; they accommodate conductor cross-sections up to 4 mm² (12 AWG) and nominal currents up to 25 A

- **Screwless Rail-Mount Terminal Blocks**

WAGO TOPJOB® S is a range of screwless rail-mount terminal blocks for building installation for conductors with cross-sections from 1.5 to 16 mm² (16 to 6 AWG)

- **Current Measurement**

Coupled with electronic interface devices and the WAGO I/O System 750, WAGO offers a comprehensive range of perfectly coordinated energy efficiency solutions

- **WAGO I/O System**

Benefits of WAGO's successful fieldbus system: a solution with scalable performance, high integration density and an unbeatable price/performance ratio

- **Pre-Assembled Custom Solutions**

WAGO's product specialists have the experience and efficient solutions to assist you from initial specs to final install

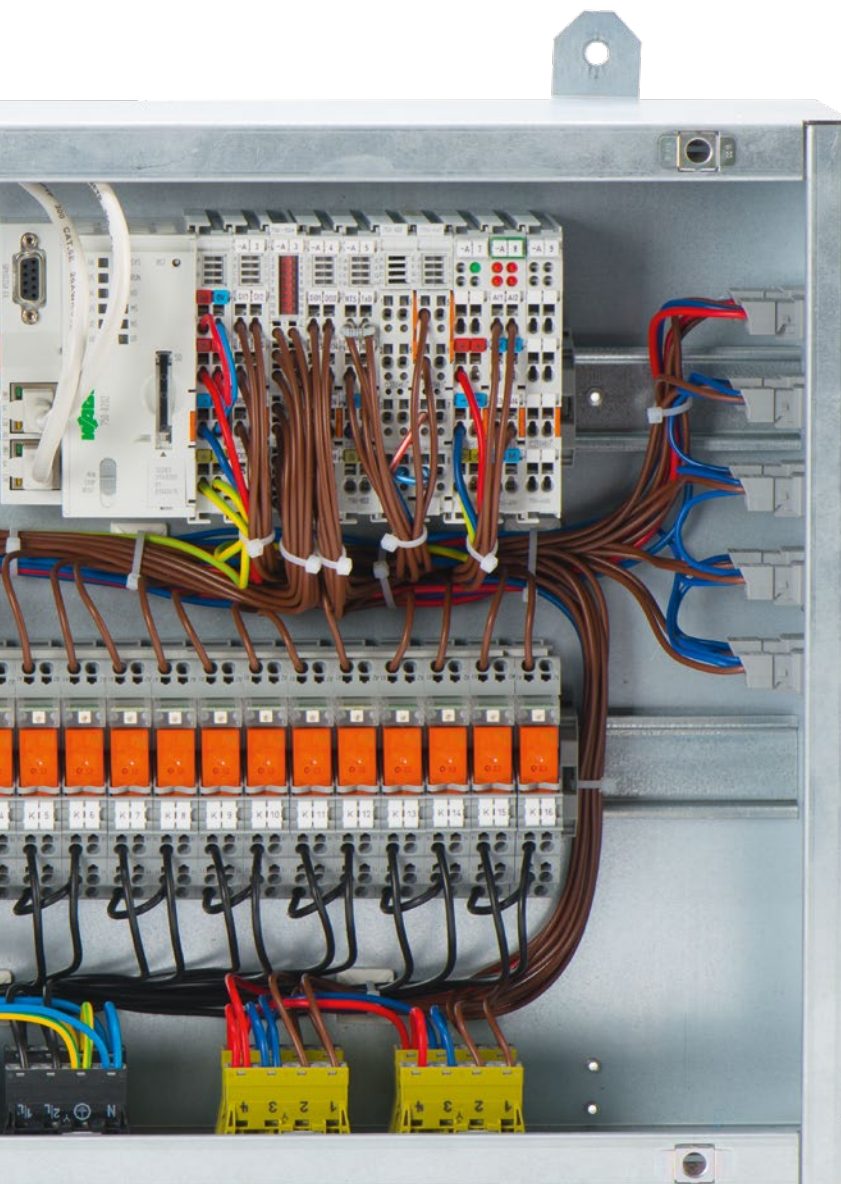



flexROOM®

A Flexible Room Solution

Our Solution

Planning, commissioning and building operation must demonstrate maximum efficiency and a high degree of adaptability. Pre-configured programs and pre-defined hardware significantly streamline planning and commissioning. The more applications created within a project, the greater the benefit. Flexible building operation (e.g., conversions and room remodeling) via special maintenance programs eliminates external service costs because the user can make their own changes.

Install, commission and configure according to project specifications – WAGO **flexROOM®** combines these strengths in one standard module. The integrated control unit and application software are precisely tailored to the room requirements.

Parameter Setting

For each room, parameters can be individually stored for lighting, shading and room control. All parameters are saved cyclically, either directly in the distribution box or on a separate computer via network connection. A higher-level management station accesses the distribution box parameters via the open Modbus TCP/IP protocol. This means all modifications can be implemented either on site or via the management station. BACnet® or KNX IP systems can also be connected via Modbus TCP/IP.

Configuring – Not Programming

Each WAGO **flexROOM®** Distribution Box has a Web interface. Both the commissioning technician and end user can configure the controls for each room via Web browser, regardless of the user's location and the distribution box used. Complete wall relocations, room assignments, and lighting and shading groups can be changed from the parameter interface. No additional software is required.

WAGO Lighting Management

The Intelligent Solution for Lighting Controllers

Modern lighting management offers more than just reduced energy consumption and costs – it combines economics and resource conservation with user comfort and flexibility.

Our Solution

WAGO Lighting Management is a proven solution based on predefined hardware and preconfigured software, which greatly simplifies planning, commissioning and operation. The basic idea: WAGO Lighting Management is ready for the vastly different light requirements of warehouses and production facilities. For example, a production facility can be divided into virtual segments in which light can be adapted flexibly. Each segment receives signals from sensors and actuators to set the appropriate light intensity automatically. With the help of these segments, it is possible to realize retrofits and room changes quickly and very easily – all through Web configuration. Besides conventional inputs and outputs, the system also supports a wide variety of technologies, such as DALI-2, EnOcean® and KNX®.

Configuration and Commissioning

WAGO Lighting Management features a Web interface that allows you to easily create and edit virtual segments. Do you need to illuminate a production line, hallway or storage area? No problem – simply create three different segments with the required functions. Parameter values are stored on an SD card or a backup server via FTP. The values can be forwarded to a higher-level building control system or a production control center via Modbus TCP/IP or OPC UA. The connection to various cloud systems is also possible and offers location-independent operation and system monitoring, including fault message management and evaluation of energy consumption data, for example.

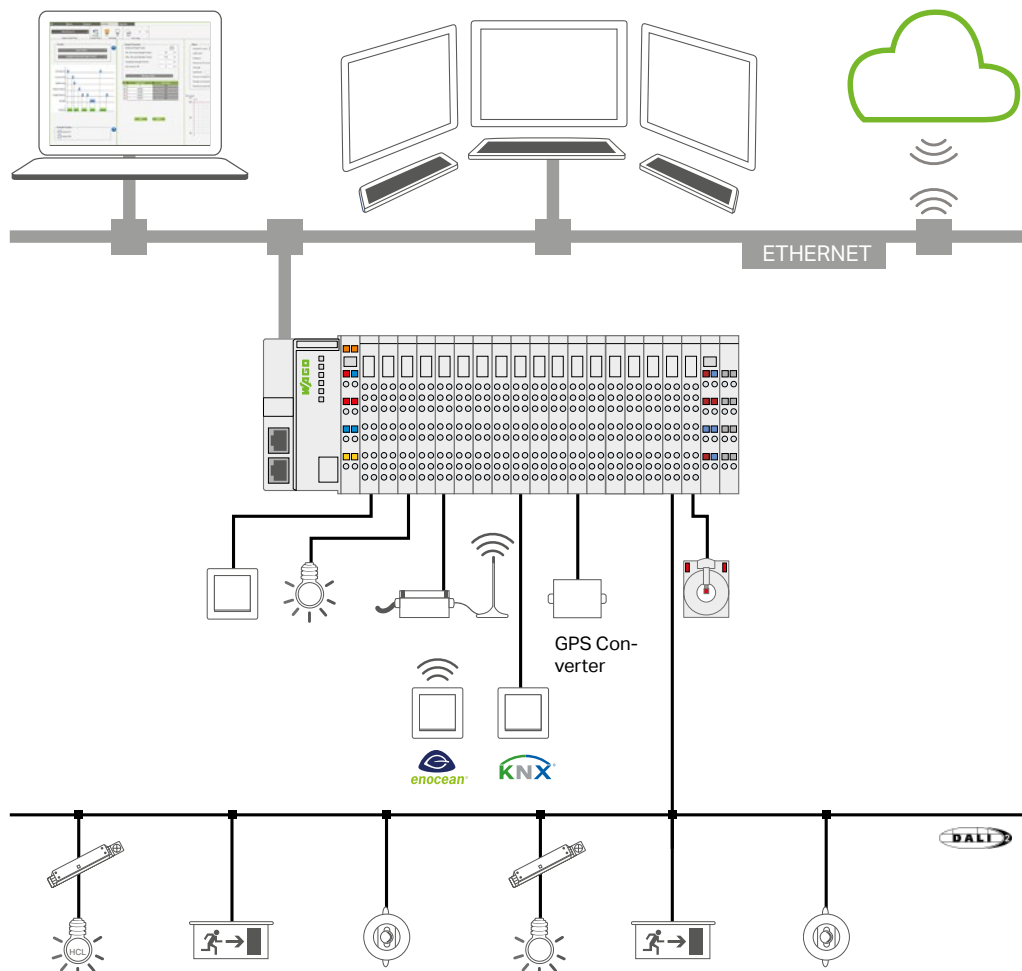

Operation

A state-of-the-art Web-based user interface is available for operation and visualization of status messages during ongoing operation. Lighting management is operated through a Web browser on a desktop computer, laptop, touch panel or mobile device, such as a tablet or smartphone.

The user interface can be set up and managed based on your individual needs. In addition to language and color settings, HMI devices, users, rooms and your own custom configuration profiles are available. The rooms in a building can be freely arranged and grouped into areas.

WAGO Lighting Management significantly reduces the overall costs of new installations and conversions. WAGO Lighting Management provides the perfect combination of high-quality hardware and intuitive custom software. Reduce lifecycle costs with quick and easy commissioning, comprehensive diagnostic and service capabilities and simple lighting adaptation to varying requirements.

Your Benefits:

- Reduce lifecycle costs through efficient lighting management
- Scalable to any system requirement
- Commissioning via self-guiding, wizard-based configuration
- Simple conversion without programming
- Connect to higher-level management and control systems within industrial or technical building environments
- Clear and convenient operation via mobile devices

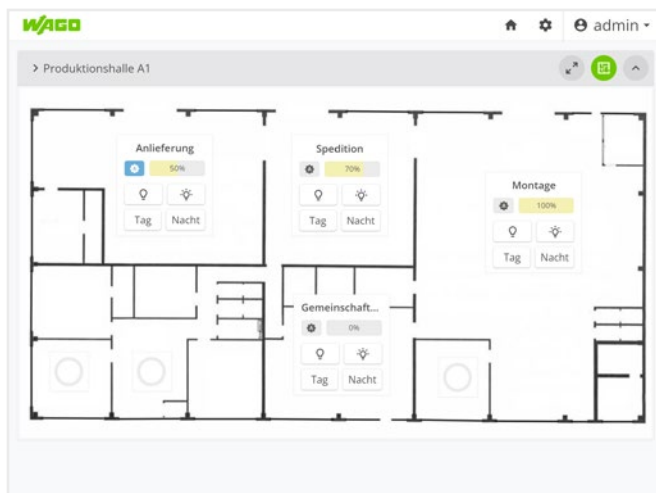
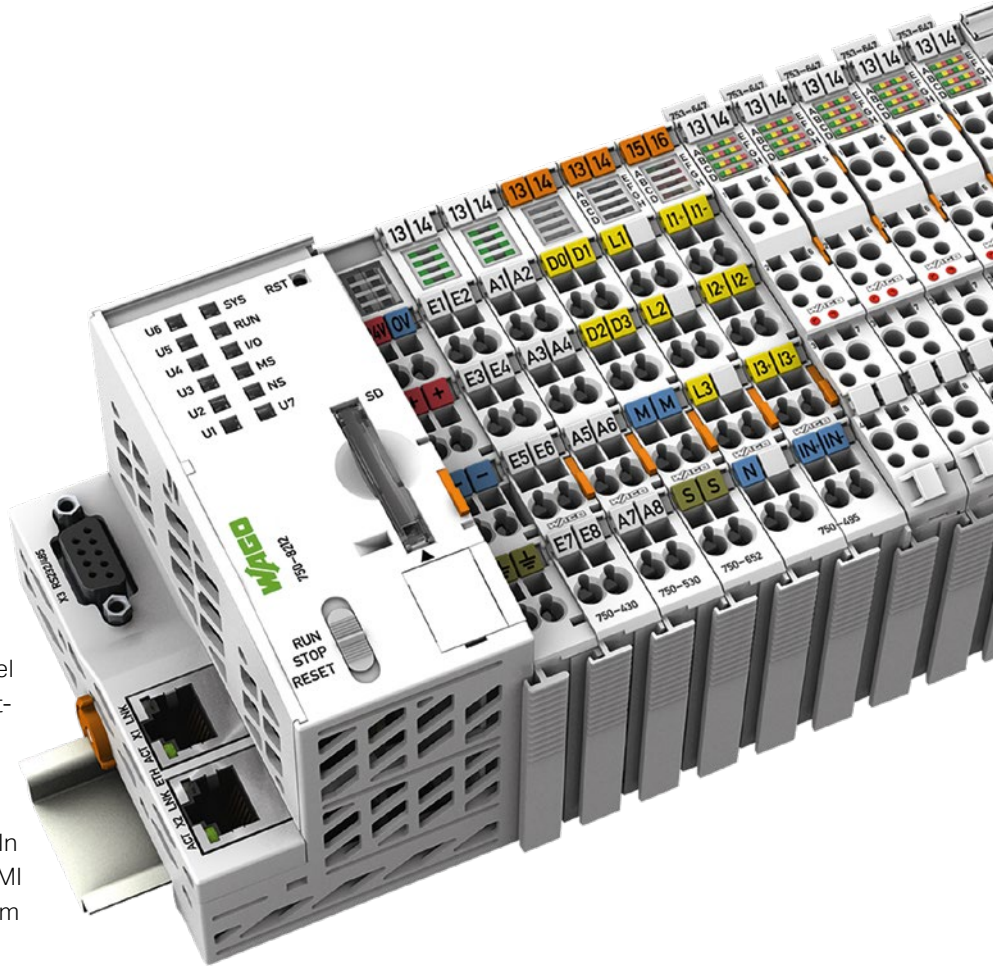

Do you need to illuminate a large area?
No problem – WAGO's lighting management application allows you to illuminate about 3000 m², depending on the type of lamp. For larger areas, it is easy to link several controllers together.

Maximum Flexibility and High Performance

KNX® is a uniform, manufacturer-independent communication protocol for intelligently networking various building automation functions. KNX® is used to plan and implement energy-efficient solutions for greater functionality and convenience in buildings.

With its freely programmable **KNX IP Controller**, WAGO offers a product that links the KNX® world with ETHERNET. Using this controller, you can link, control, regulate and monitor all types of KNX® devices from various building systems. When paired with the I/O modules from the WAGO I/O System 750, other sensors, actuators and sub-buses like DALI and EnOcean® can be easily integrated into the controller.

The **KNX TP1 Module** connects KNX TP1 networks to the WAGO I/O System and is compatible with all building-related WAGO Controllers (e.g., BACnet).

Combining a **KNX IP Controller** with a **KNX TP1 Module** creates a router that automatically connects the KNX system to ETHERNET. This provides tremendous freedom to conveniently operate buildings or systems via the Internet – wherever you are.

WAGO ETS Plug-in

The ETS standard programming tool assigns group addresses and commissions WAGO KNX® products. WAGO's specially developed plug-in supports users in configuring the KNX interface.

Additional Benefits

WAGO's innovative KNX® components are seamlessly integrated into the WAGO I/O System. This provides a wide range of input, output and specialty modules for sub-bus systems such as DALI, as well as controllers for higher-level networks such as BACnet. Cost-effective control units replace several individual KNX® components as room and area controllers. The KNX® standard provides communication with thousands of devices from other manufacturers.

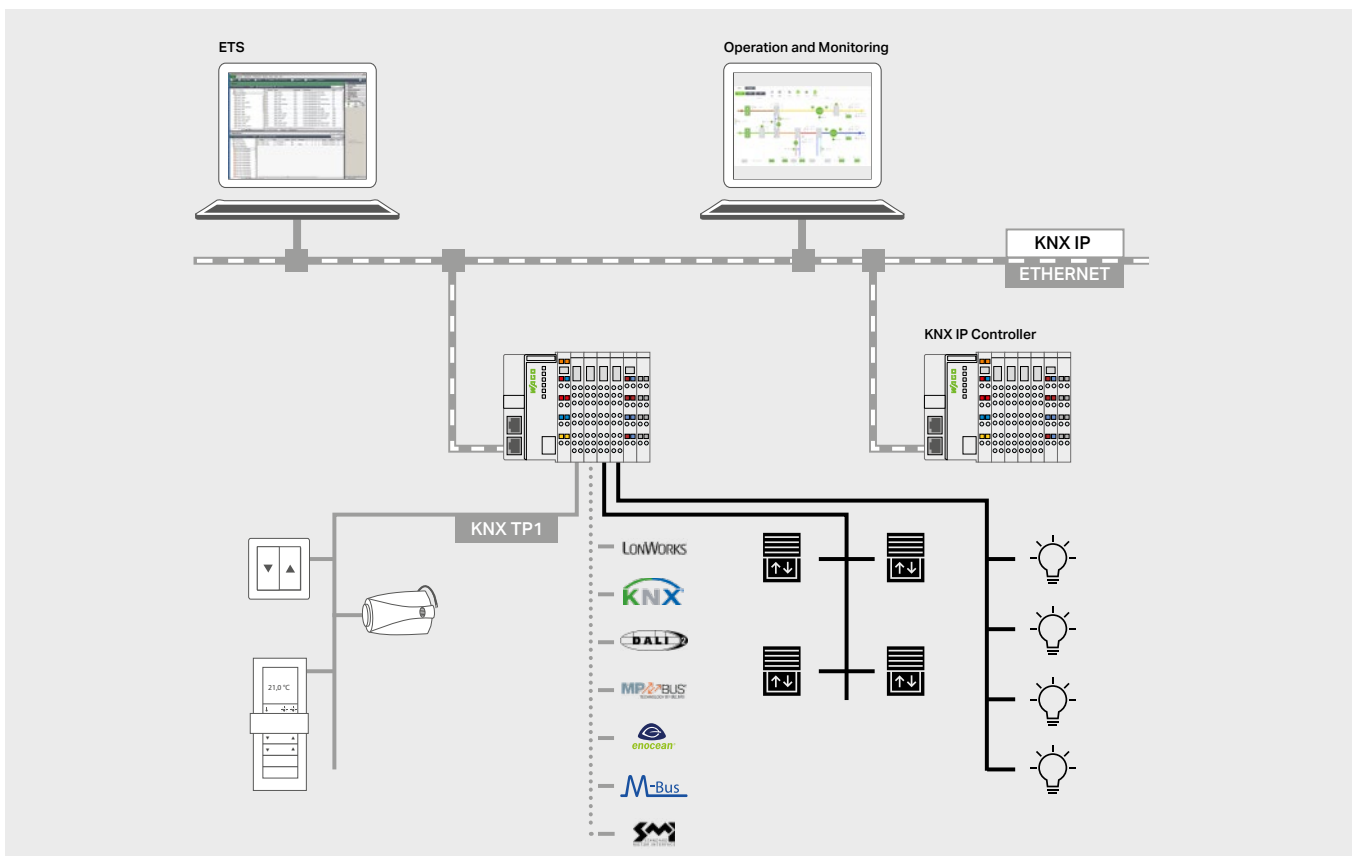

BACnet®



A Fast Control Solution for Complex Applications

BACnet® is a standardized building automation communication protocol that adheres to DIN EN ISO 16484-5. BACnet® standardizes communication between products from different manufacturers. To achieve this, the standard defines device profiles, services, communication objects, object properties and transmission media. WAGO's BACnet® Controllers comply with the BACnet Building Controller (B-BC) profile and communicate via **BACnet/IP** or **BACnet MS/TP**.

WAGO BACnet® Configurator

The BACnet® Configurator is useful for configuring and operating BACnet® Controllers in a heterogeneous BACnet® network. Tasks such as logically structuring the network, addressing the controller, and configuring both client and server can be performed on the configuration interface. In addition, the properties of BACnet® objects can be accessed using a Web browser.

Additional Benefits

Beyond "BACnet Building Controller" (B-BC) profile compliance as defined in the BACnet® Standard, WAGO's freely programmable BACnet® Controllers are compatible with

the associated BACnet® Interoperability Building Blocks (BIBBs). A large variety of available input, output and specialty modules for sub-buses such as KNX®, MP-Bus and DALI complete the system, making WAGO BACnet® Controllers incredibly versatile.



Tested and Certified

Manufacturers of BACnet® products can take advantage of conformity tests at recognized, accredited test agencies to prove their devices comply with BACnet® Standard ISO 16484-5/ANSI ASHRAE 135.

WAGO's BACnet® Controllers are certified by independent test laboratories and carry the globally recognized BTL logo!

We also meet special requirements of local markets, such as the AMEV certificate. If you have questions about tests or certificates, please contact us! A large variety of available input, output and specialty modules for sub-buses such as KNX®, MP-Bus and DALI complete the system, making WAGO BACnet® Controllers incredibly versatile.

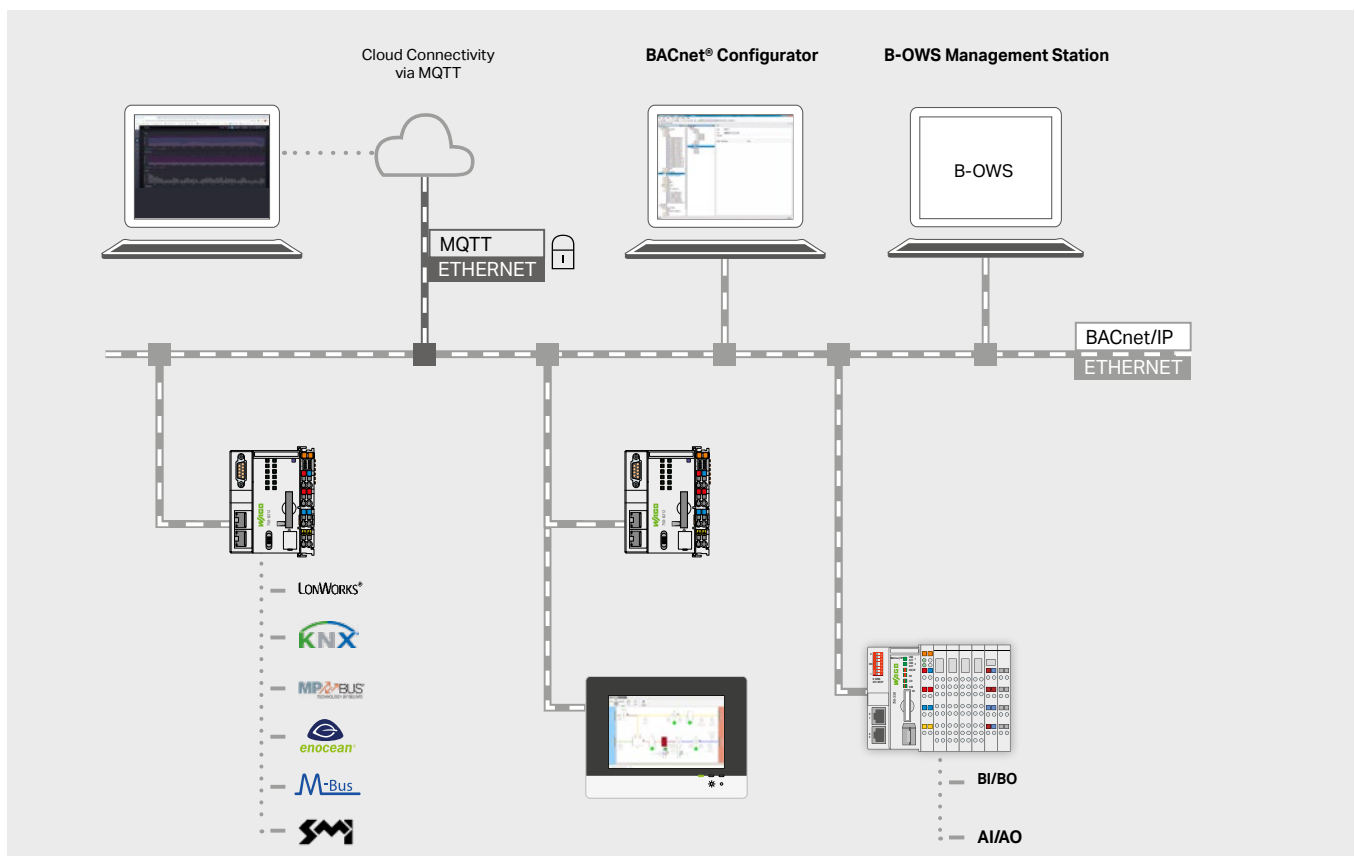



DALI-2

Flexible Solutions and Simple Commissioning

DALI stands for “Digital Addressable Lighting Interface” and is a protocol defined in IEC Standard 62386. The DALI standard, a protocol common to all manufacturers, replaces the 1–10 V dimmer interface and ensures the interoperability of DALI devices (e.g., electronic control gears in lighting applications). A DALI master can control a line with up to 64 devices. In addition, sensors for brightness measurement and presence detection, for example, can be integrated into a DALI network.



A DALI system allows individual lights or lighting groups to be controlled. No parallel wiring of the control groups is necessary. Assigning individual lights to operating elements and grouping of lights can also be done after installation and is possible at any time without re-wiring.

The DALI-2 standard was published within the scope of IEC 62386, which defines both the operating devices and the requirements for control devices – among them, the WAGO **DALI Multi-Master Module**. In combination with controllers and I/O modules from the WAGO I/O System, even complex DALI lighting applications can be realized. In addition, the module can function as an interface to numerous fieldbus and sub-bus systems. There is no need to install an additional sensor bus since sensors can be easily integrated into a DALI network.

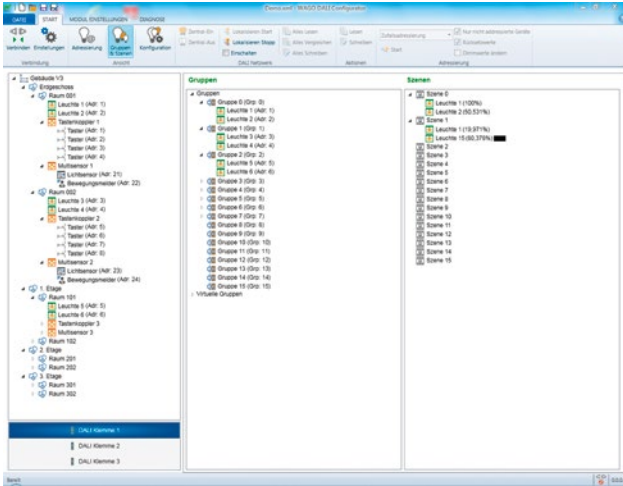

DALI network devices are configured and commissioned using WAGO's DALI Configurator. This tool includes comprehensive functions that simplify and streamline both the installation and maintenance of a DALI network. These functions include addressing and configuring all DALI network devices, group and scene formation and comprehensive diagnostics.

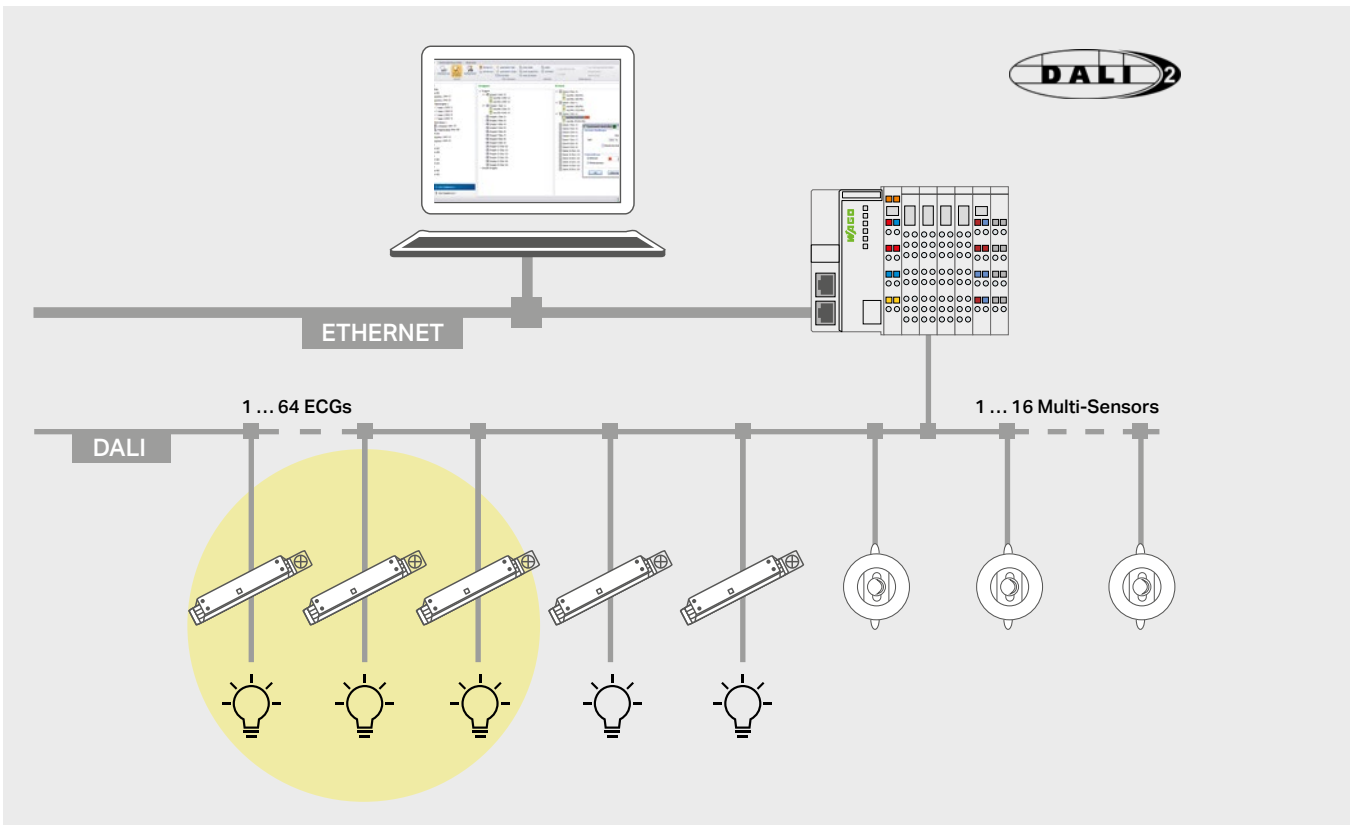

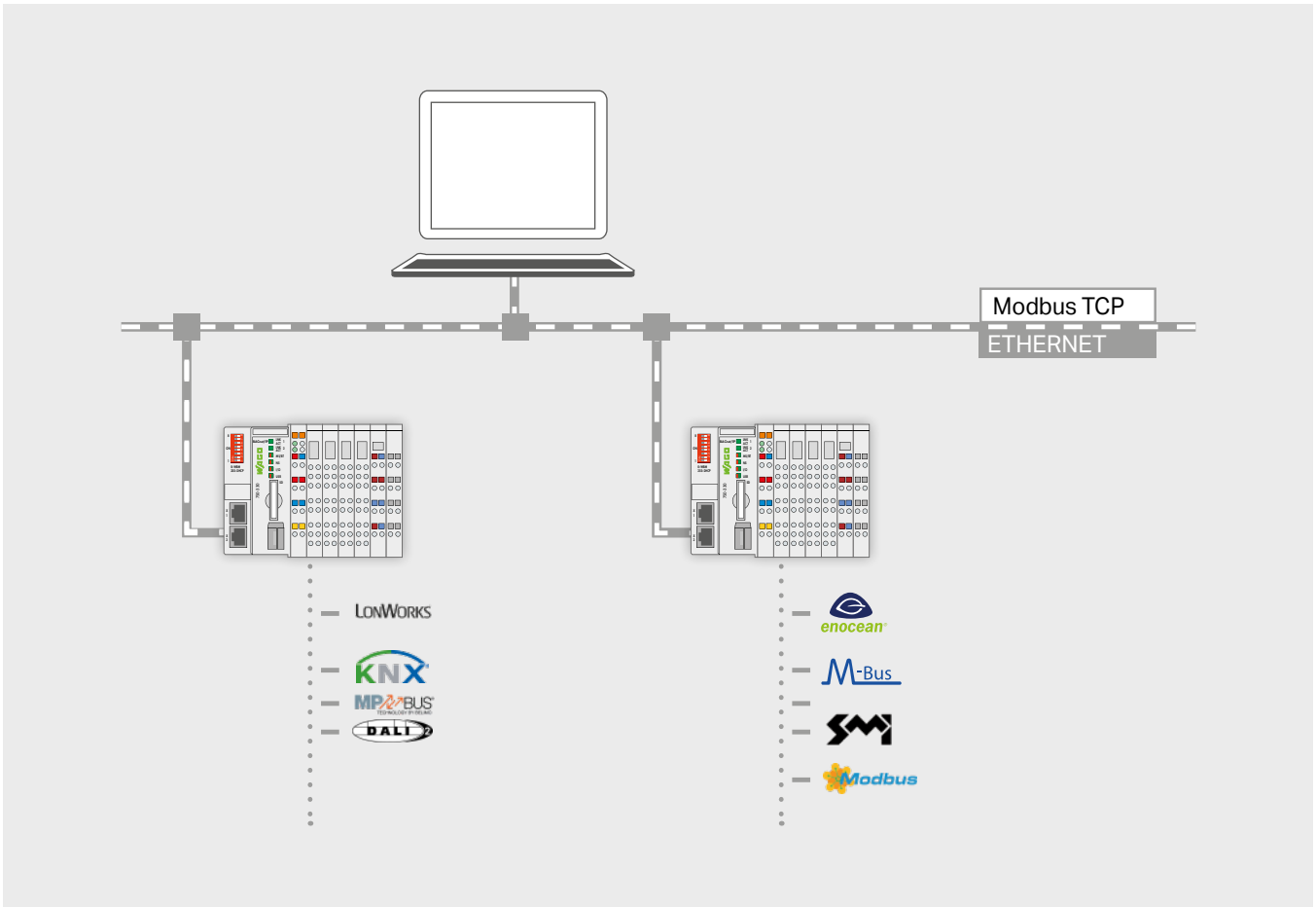

Modbus TCP/IP

Fast and Lean Communication

Extending 1979's Modbus TCP protocol for PLCs, the well-established Modbus® protocol has become the de facto standard for building automation. The advantage: Modbus® is a streamlined protocol that ensures ultra-fast ETHERNET data transmission. A manufacturer-independent data structure also permits communication between devices from different manufacturers.

Thus, Modbus TCP is recommended for applications that collect data and/or network intelligent controllers with self-sufficient control logic. Therefore, in addition to the respective fieldbus protocol, WAGO's ETHERNET-based controllers for building automation also support Modbus TCP.



Cybersecurity Right in the Switch

Industrial Managed Switch with Built-in Encryption Feature

Cybersecurity is an important issue in automation technology. With WAGO's new switches, users can easily increase the security of their applications. This innovation integrates cybersecurity functions: Any data packets undergo 128-bit encryption on two ports. That makes it possible to integrate secure data transmission into an existing network – regardless of the protocol and without application changes. The encryption meets the IEEE 802.1AE standard (IEEE MAC Security Standard), ensuring data integrity and sender authentication alongside high data throughput.

Your Benefits:

- Increase network security without in-depth IT knowledge
- Data integrity via hardware-based encryption
- Optional authentication of network subscribers
- Network diagnostics via Modbus® or SNMP
- Potential-free communication with SFP modules (up to 80 km)

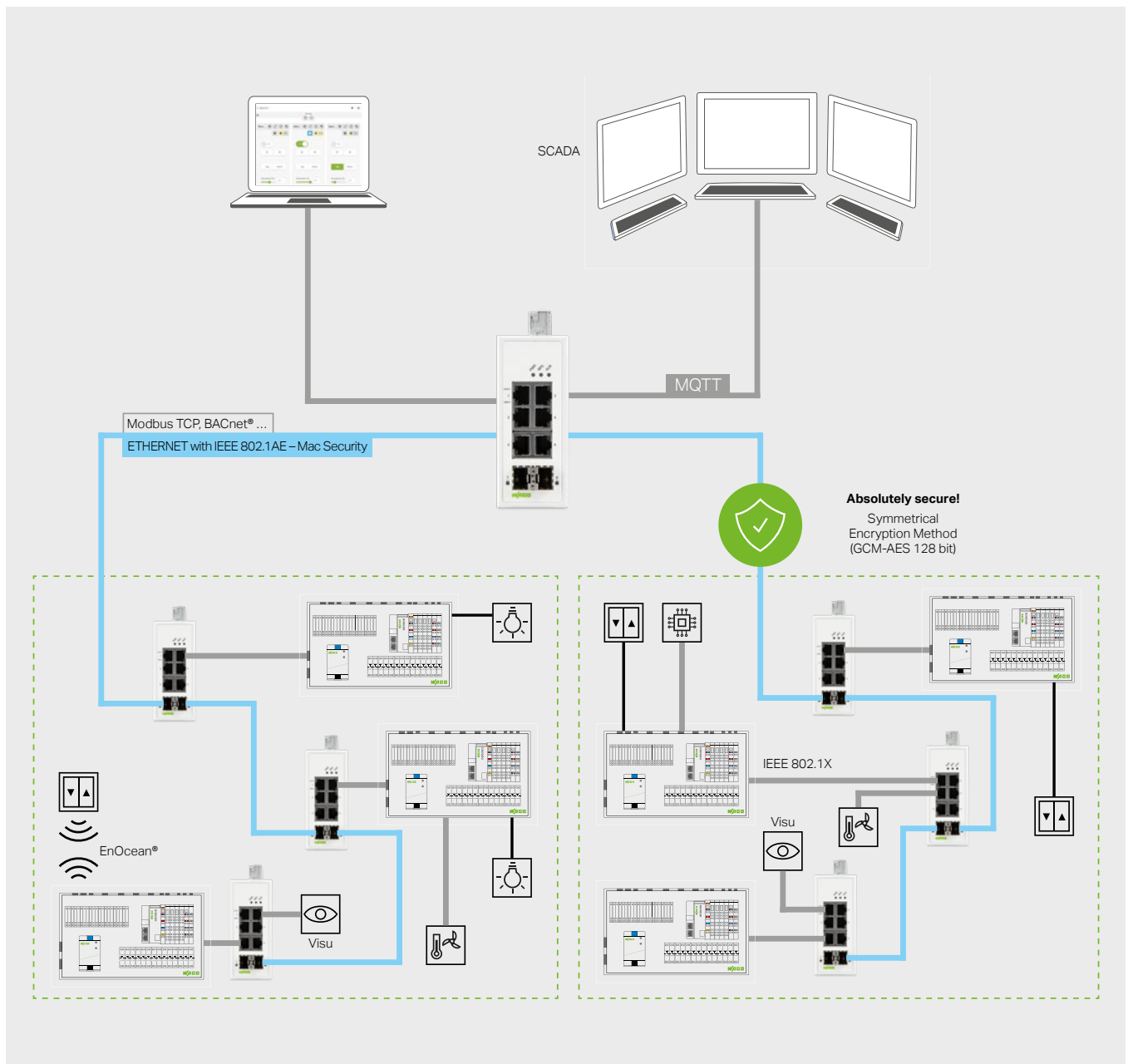

SMI Master

Connect Electrical Drives Directly

A compact design paired with advanced technology: The SMI Master Module (753-1630) for the WAGO I/O System 750 allows direct connection of electric drives for sunblinds or roller shades without a level inverter.

In addition to reduced wiring expenses, using the new SMI Master also minimizes other costs. A prime example: Since the module has an integrated power supply, an external one is no longer necessary. In addition, a digital output temporarily deactivates the drives when they are not needed.

The SMI Master Module (753-1630) controls 230 VAC SMI motors, and the 753-1631 model can be used with low voltage sunblind drives (24 V). Up to 16 drives can be connected per module. The SMI Master Module also offers users numerous helpful functions. For example, the "auto-replace" function allows building operators to replace a defective motor without modifying the configuration.

WAGO also offers a new SMI Configurator to design and commission SMI networks. The software is used to quickly address the SMI drives and to expedite both the import and export of all configured drives.



EnOcean® Radio Technology

Innovative Solutions for Building Automation

WAGO's EnOcean® radio technology opens up a new level of innovative building automation solutions, both technically and aesthetically. Wireless switches and sensors based on EnOcean® technology harvest available energy to power themselves, e.g., kinetic energy from actuating a switch, or sensors powered by temperature variations or ambient light.

Each transmitter has a unique address and communicates with a receiving unit. Despite the limited energy available,

these highly efficient electronics can transmit the signal multiple times, guaranteeing high transmission reliability.

The EnOcean® Dolphin system architecture expands the previous system architecture to include sensors and actuators that communicate bidirectionally. The interoperability of EnOcean® Dolphin makes it possible to combine products from different manufacturers into one advanced system.

The WAGO EnOcean® Gateway (750-940) also allows easy connection to the WAGO I/O System 750 via a serial interface. Connection is established either via a WAGO I/O System's serial module or a controller with an integrated serial interface. The use of standard protocols like Modbus® and ESP-3 simplifies bidirectional communication between the WAGO I/O System and the EnOcean® modules. Serial transfer also allows long cable lengths, so the gateway (750-940) can be installed far from the WAGO I/O System.

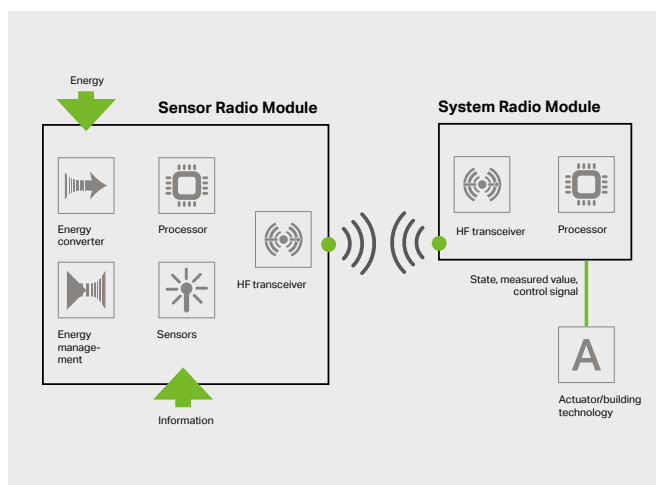

M-Bus Master

Connect Energy and Consumption Meters Directly

Reduce costs, simplify installation, and save space: The M-Bus Master Module (753-649) directly connects up to 40 M-Bus devices to the WAGO I/O System to capture consumption data – without external gateways and level inverters.

The M-Bus system, based on a master/slave communication model, can be operated as a line, star or tree topology.



A WAGO Controller with the M-Bus module, which communicates with bus components via 2-wire bus, plays the role of the master. Up to 40 slaves can be connected per module. The M-Bus transmits data at speeds of 300 to 9600 bps. Regular type J-Y(St)Y N x 2 x 0.8 mm telephone cable, for example, can be used as the M-Bus cabling.

MP-Bus Master

Control HVAC Actuators

The MP-Bus controls HVAC actuators for dampers, regulator valves and air volume controls.

MP-Bus actuators have an input for direct connection of sensors, such as temperature, humidity and potential-free contacts. Devices that are equipped with an MP-Bus connection can communicate with a higher-level control system via bus cable.

Up to eight actuators can be controlled by an MP-Bus master. An MP-Bus master like the MP-Bus Master Module (750-643) can manage up to eight slaves (actuators) + eight sensors (one sensor per slave) via a common bus line, which considerably reduces actuator and sensor wiring. MPL drives are also supported. Of these, up to 16 actuators can be operated on one MP-Bus master. There

is no line topology limitation – star, ring, tree or mixed configurations are possible. Up to eight slaves can be connected to a master. The actuators feature Multi-Function Technology (MFT) and include damper actuators, MFT(2) valve actuators, MFT fire damper actuators, VAV compact controllers and Belimo's FLS window ventilation system. Data can be exchanged between a master and the slaves, such as absolute/relative volumetric flow, minimum/maximum limits, angular position, sensor value, operating status and fault messages.





Touch Panels 600

Three Function Classes

Operation, monitoring and diagnostics in buildings: Touch panels with different display sizes in the Web Panel, Visu Panel and Control Panel variants, combine a contemporary design with impressive features and are available for small- to mid-sized control and visualization tasks.

Web Panel

Web Panels are provided with an optimized Web browser for accessing controllers via standard Web protocols with integrated Web visualization for display. They can display Web visualizations created with **e!COCKPIT** and based on state-of-the-art technology like HTML5.

Visu Panel

Visu Panels are suitable for direct display of a visualization generated with **e!COCKPIT** and for retrieving the data it references from PFC200 Controllers or other field devices via Modbus TCP. These panels can also provide a Web visualization via the integrated Webserver.

Control Panel

Control Panels allow simultaneous execution of a control and visualization task generated with **e!COCKPIT**, offering a very compact automation solution. Using a dedicated library, these panels become IoT controllers that send data from the field level to the cloud.

Additional Technologies

The WAGO I/O System gives users many interface solutions for building automation bus systems and subsystems. Beyond the previously mentioned protocols, WAGO also supports:

LonWorks® is standardized under ISO/IEC 14908 and is an important technology used worldwide for existing projects in building automation. It enables interoperable communication between devices from different manufacturers.

DMX is a digital protocol used to control lighting or special stage effects. With the rapid deployment of LED lighting technology, DMX is also used to control LED lights in commercial and utility buildings. DMX displays its strengths in RGB color-control applications, e.g., facade illumination.

LONWORKS®

DMX

Note

Technical Support

www.wago.com/support

Project Support

Find our contact partners at:

www.wago.com/building_technology

WAGO Seminars

www.wago.com/seminars



WAGO GmbH & Co. KG

Postfach 2880 · D-32385 Minden
Hansastraße 27 · D-32423 Minden

info@wago.com

www.wago.com

Headquarters	+49 (0)571/ 887 - 0
Sales	+49 (0)571/887 - 44 222
Orders	+49 (0)571/ 887 - 44 333
Fax	+49 (0)571/887 - 844 169

WAGO is a registered trademark of WAGO Verwaltungsgesellschaft mbH.

“Copyright – WAGO GmbH & Co. KG – All rights reserved. The content and structure of the WAGO websites, catalogs, videos and other WAGO media are subject to copyright. Distribution or modification of the contents of these pages and videos is prohibited. Furthermore, the content may neither be copied nor made available to third parties for commercial purposes. Also subject to copyright are the images and videos that were made available to WAGO GmbH & Co. KG by third parties.”