



# Automotive Industry

Applications and Solutions



Please contact the WAGO Global Automotive Team:  
[automotive@wago.com](mailto:automotive@wago.com)

# Content

The Automotive Plant	<b>4</b>
We are WAGO	<b>6</b>
Edge Computing for the Control Cabinet and Factory Levels	<b>8</b>
Our Modules for Controlling Your System	<b>10</b>
New Paths in Engineering	<b>12</b>
WAGO Hardware – Countless Software Options	<b>14</b>
Device and Application Management	<b>16</b>
Connecting Existing Controllers to the IoT Infrastructure	<b>17</b>
The Stamping Plant	<b>18</b>
Energy Data Acquisition with WAGO	<b>20</b>
The Body Shop	<b>22</b>
The WAGO I/O System Field, IP67	<b>24</b>
Extended Network Connectivity	<b>28</b>
Safety First – Functional Safety	<b>30</b>
The Paint Line	<b>34</b>
Explosion Protection – Made by WAGO	<b>36</b>
The WAGO I/O System 750	<b>38</b>
The Powertrain	<b>40</b>
The WAGO Pro 2 Power Supply	<b>42</b>
Secondary-Side Fusing	<b>46</b>
Industrial Managed Switches	<b>48</b>
RJ-45 Connector	<b>50</b>
Lean Managed Switches	<b>52</b>
Final Assembly	<b>54</b>
Buildings	<b>56</b>
HVAC Primary System Solutions	<b>58</b>
Lighting Management	<b>60</b>
A Measurement System with Added Value – Energy Management	<b>62</b>
Cloud Connectivity	<b>64</b>
External Suppliers	<b>66</b>

# The Automotive Plant

Benefits along the Entire Value Added Chain – with WAGO

4. THE POWERTRAIN

1. THE STAMPING PLANT

3. THE PAINT LINE

8. SUPPLIERS



7. EVALUATION VIA THE CLOUD

2. THE BODY SHOP

5. FINAL ASSEMBLY

6. BUILDINGS

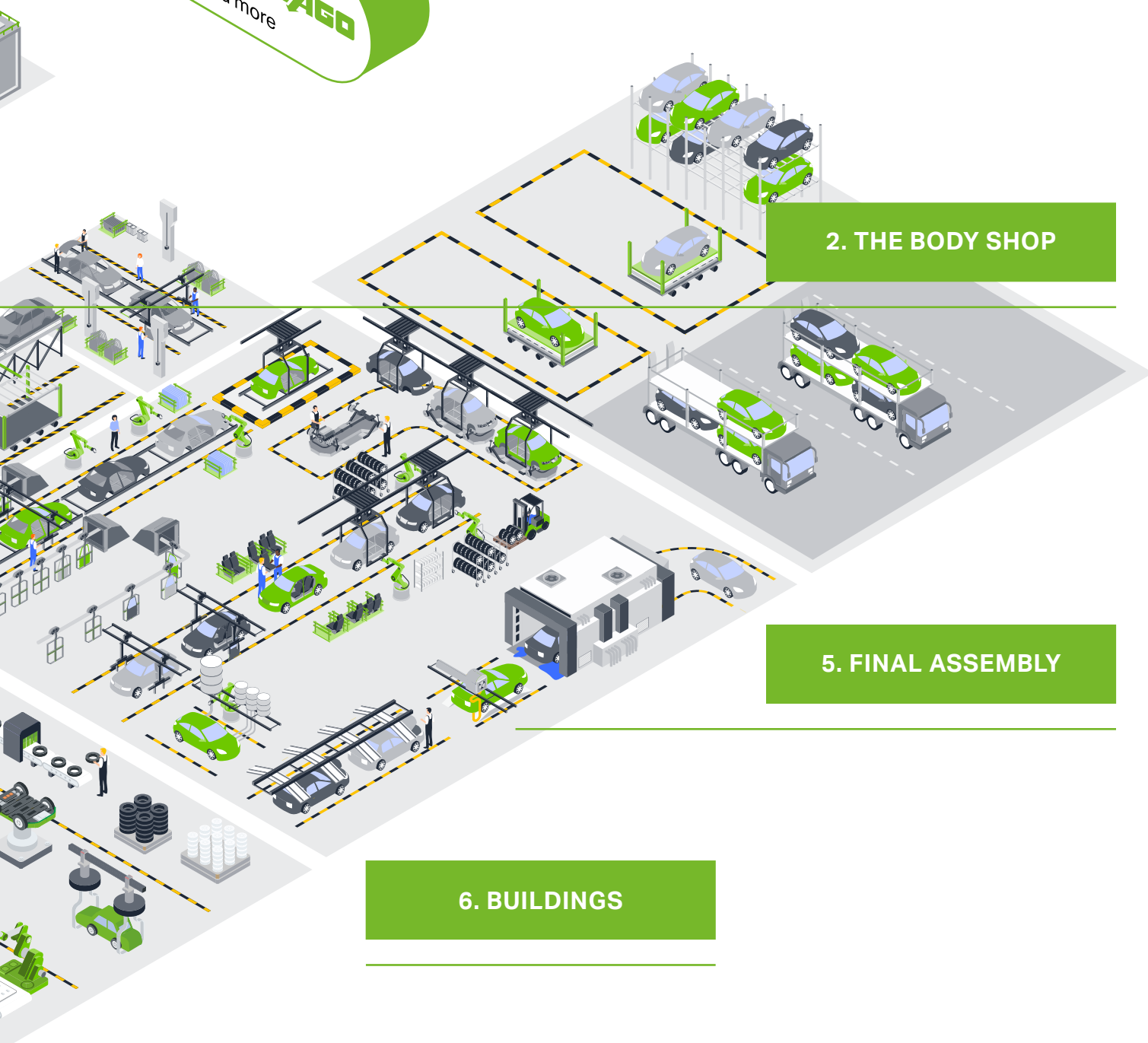



## We are WAGO

**Data and energy flows are part of the digital world's infrastructure; with our WAGO products, we want to make sure this foundation continues to function in the long term.**

We have always viewed ourselves as a reliable partner for industry and are aware of the tremendous responsibility we have as a leading provider of electrical interconnection and automation technologies. We face this challenge with passion and commitment, because it is part of our corporate vision and mission.

WAGO works with you to shape the digital future: The automotive industry is using cloud solutions more today than ever before. They link the real and digital worlds, allow efficient use of production-related data and simplify cross-site networking within a company.

This creates many new opportunities for the automotive industry – especially for the system availability and process optimization that are so essential here.

# WAGO Enables Digital Factories

The production line of the future will not only be networked and intelligent – it will also possess some autonomous control and optimization capabilities, making it resource-efficient. For the transformation to an “intelligent factory,” the existing processes are networked together and all the product, machine and process data is recorded. Automation solutions like the WAGO I/O System 750 are available for collecting and securely transferring data into a “Manufacturing Execution System” (MES) or product management system.

## From the Sensor to the Cloud

Digitization and its various facets, such as IIoT, Industry 4.0, predictive maintenance and digital twins, describe an essential process: Distributed field data is collected, processed and then made available as needed to different users in the IT network for further analysis.

Learn more:



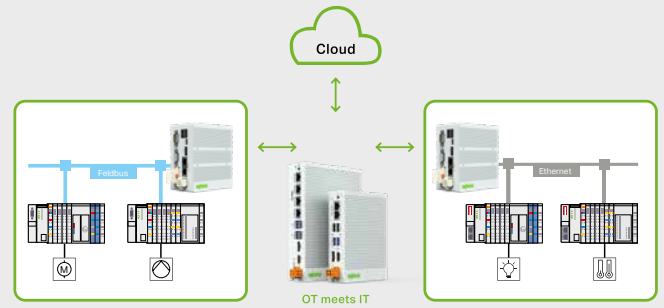
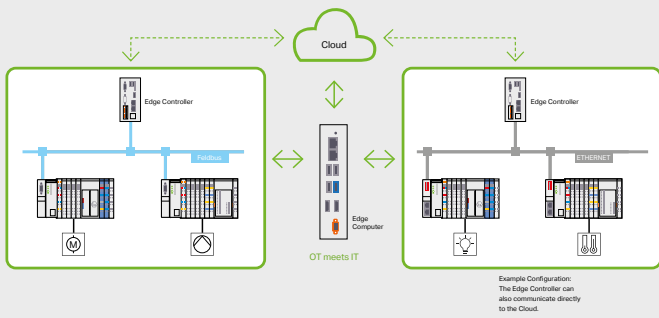

# Edge Computing for the Control Cabinet and Factory Levels

## Easy Cloud Connection

**Transferring data from machines and systems directly to a cloud solution is often too resource-intensive and cannot be implemented without sacrificing performance, because industrial environments require low latency.**

Edge computing combines the advantages of decentralized cloud architectures with those of a local network architecture and has become an established approach. This approach allows digitization right in the control cabinet, helping optimize factories and increase their efficiency.

With more computing power, WAGO Edge Devices allow fast,

targeted processing of machine data right in the field. Depending on their specific uses, individual edge devices can communicate via standardized protocols, such as Modbus TCP, OPC UA on a PI server or directly via MQTT with a cloud. In some cases, it makes sense to combine multiple edge devices in order to optimize a network. Moving the optimization “on premises” offers the option of individual customization right on the system and reduces the data burden on the IT network.

### WAGO Edge Computer

- Multi-core industrial computers (Debian 10 Linux)
- 752-9401 and 752-9400
- Intel Atom E3845 quad-core 1.91 GHz
- 4 GB or 8 GB of RAM / 64 GB of flash memory
- 2 × 10/1000 Mbit RJ45, 3 × USB-A, 1 × USB-A 3.0, 1 × HDMI, 1 × Display Port
- TPM2 0 chip

#### The Benefits for You:

- High computing power, scalable storage
- Compact, low-maintenance
- Allows use of standard software (with USB load)







## WAGO Edge Controller

- Quad-core performance
- 752-8303/8000-002
- ARM Cortex A9 quad-core 1 GHz processor
- 4 configurable DIOs
- microSD card
- 1 × serial, 1 × CAN port, 1 × HDMI, 2 × USB-A, 1 × USB-C

### The Benefits for You:

- Control and data processing in one device
- Low latency with real-time patch
- Docker technology support
- Option of using Web and Target Visu
- Supported fieldbus protocols: Modbus TCP, CANopen, EtherNet/IP Adapter
- Optional: Multi-Cloud, Sparkplug, OPC UA Server Extended, BACnet, EtherCAT Master, EtherNet/IP Scanner, Telecontrol
- IoT-ready thanks to MQTT and OPC UA
- High energy efficiency: max. 2.9 W / 9.4 W (with USB load)

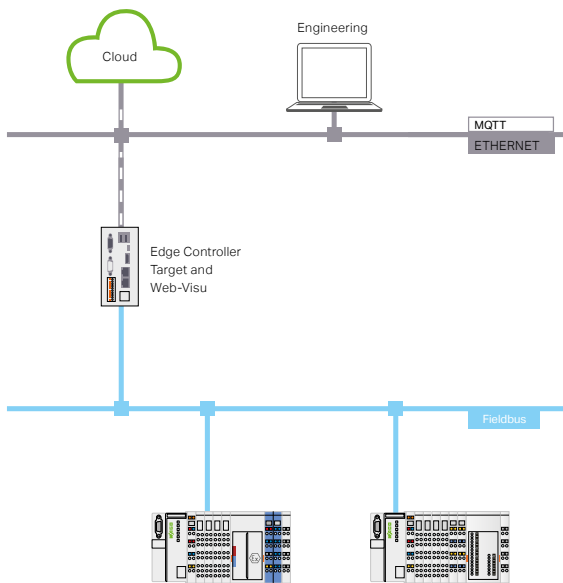

Scan QR code for data sheet  
and  
downloads



# A Ready-to-Use Solution Right on the Machine

## The WAGO IoT Box

**What if you don't have a control cabinet nearby and want to locate the edge devices right on the machine?  
No problem: Use our WAGO IoT Box.**

This allows you to easily integrate machines and systems into the "Internet of Things," in both new and existing systems. The complete system is ready for immediate use and offers all the functions required for digitization, from signal acquisition to cloud connectivity. Setting a few parameters is all that is required in order to get the data to the desired IoT application. The hardware includes a controller with its own communication interface, I/O modules with analog and digital inputs/outputs, a 3-phase power measurement module and a 24 V power supply unit. Depending on the application, additional I/O cards can be added later to adapt the system to specific requirements. Do you need a custom solution?

Our Solutions Team will be happy to help:  
[solutions@wago.com](mailto:solutions@wago.com)



# Our Modules for Controlling Your System

1-, 2-, 4-, 8- and 16-Channel

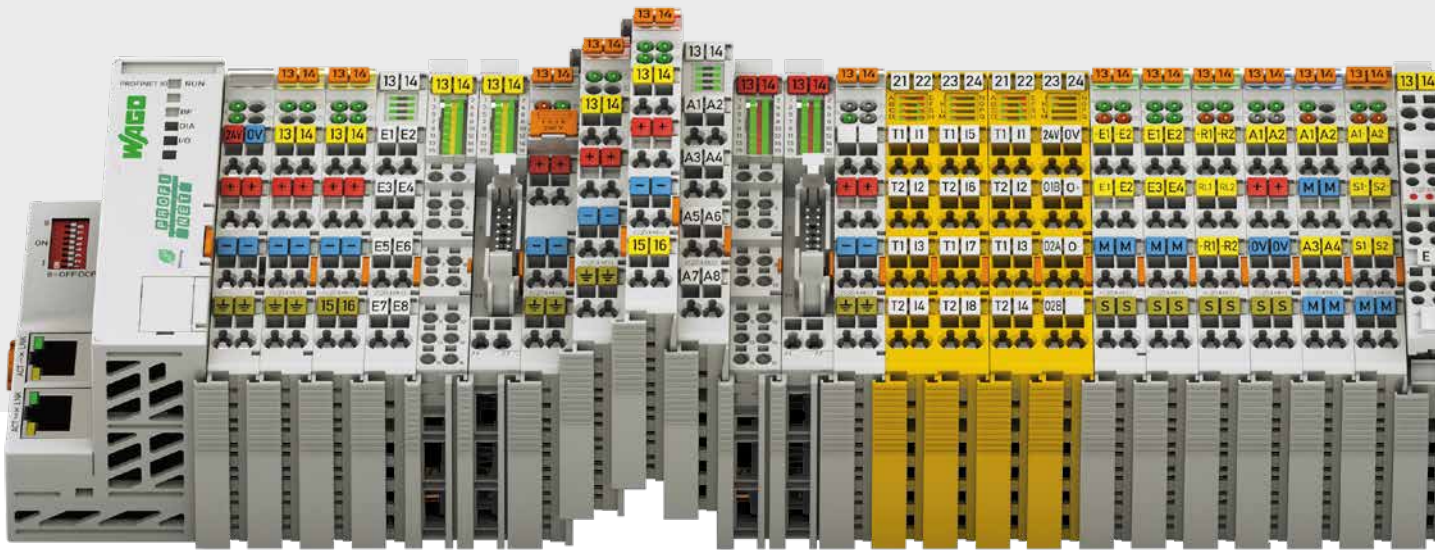

## Digital Input Modules

### 2-Channel Digital Input

- 24, 48, 60, 110, 220 VDC
- 120, 230 VAC
- NPN/PNP, 0.2 ms/3.0 ms filter, diagnostics

### 2-Channel Digital Specialty Modules

- NAMUR
- Pulse extension
- Intruder detection
- Up/down counter, 500 Hz, 100 kHz

### 4-Channel Digital Input

- 5, 24, 42 VDC
- 24, 42 VAC, 110 ... 230 VAC

### 8-Channel Digital Input

- 24 VDC, 5 ... 14 VDC
- NPN/PNP, 0.2/3.0 ms, filter
- PTC

### 16-Channel Digital Input

- Push-in CAGE CLAMP®, 24 VDC, NPN/PNP
- Ribbon cable, 24 VDC, NPN/PNP

## Digital Output Modules

### 1-Channel Digital Output

- 440 VAC, 16 A
- Manual operation, bistable

### 2-Channel Digital Output

- 24 VDC, 0.5 A/2 A, diagnostics (wire break/short circuit)
- 230 VAC, SSR, 3.0 A, diagnostics

### 4-Channel Digital Output

- 5 VDC, 24 VDC, 0.5 A
- 120 ... 230 VAC, 0.25 A
- NPN/PNP, diagnostics

### 8-Channel Digital Output

- 5 ... 14 VDC, 1 A
- 24 VDC, 0.5 A
- NPN/PNP, diagnostics

### 16-Channel Digital Output

- Push-in CAGE CLAMP®, 24 VDC, 0.5 A, NPN/PNP
- Ribbon cable, 24 VDC, 0.5 A

### 2-Channel Relay Output

- 0 ... 230 VAC/DC
- 2 make contacts/2 changeover contacts, isolated outputs/non-floating

### 4-Channel Relay Output

- 4 make contacts

## Analog Input Modules

### 1-Channel Analog Input

- Resistor bridge (strain gauge)

### 2-Channel Analog Input

- 0/4 ... 20 mA, 0 ... 1/5 A AC/DC
- 0 ... 10 VDC,  $\pm 10$  VDC, 0 ... 30 VDC
- Thermocouples
- Resistance measurement (RTD)
- Differential/single-ended input
- Measurement input (galvanic isolation)
- Modules with HART protocol (NE43)

### 4-Channel Analog Input

- 0/4 ... 20 mA
- 0 ... 10 V,  $\pm 10$  V
- Resistance measurement (RTD)
- Single-ended input
- Measurement input (galvanic isolation)

### 8-Channel Analog Input

- 0 ... 10 V,  $\pm 10$  V
- 0/4 ... 20 mA
- Thermocouples
- Resistance measurement (RTD)
- Single-ended input
- Push-in CAGE-CLAMP® connection technology

### 3-Phase Power Measurement

- 480/690 V, 1 A/5 A/20,000 A/Rogowski coil



More information on our  
I/O systems:



## Analog Output Modules

### 2-Channel Analog Output

- 0 ... 10 V/±10 V
- 0/4 ... 20 mA

### 4-Channel Analog Output

- 0 ... 10 V/±10 V
- 0/4 ... 20 mA

### 8-Channel Analog Output

- 0 ... 10 V/±10 V

### Analog Specialty Modules

- 6 ... 18 V
- 0 ... 10 V, 10 mA, diagnostics

## Function and Technology Modules

### Counter Modules

- Up/down counter
- Frequency counter
- Peak-time counter

### Distance and Angle Measurement

- SSI transmitter interface
- Incremental encoder interface
- Digital impulse interface

### Positioning

- Stepper controller, RS-422
- Stepper controller, 24 V/1.5 A
- Stepper controller, 70 V/7.5 A, 6IN/2OUT
- Servo stepper controller, 70 V/7.5 A, 6IN/2OUT
- DC drive controller, 24 V/5 A

### Pulse Width Output

### Proportional Valve Module

- Control of hydraulic or pneumatic valves

### Vibration Monitoring

- Vibration velocity/bearing condition monitoring

### RTC Module

- DCF77 radio receiver

**CODESYS 3**



## New Paths in Engineering

### **The Right Automation Environment for Every Application**

WAGO has continued to develop its engineering; it now uses the manufacturer-independent CODESYS V3 programming environment and has introduced WAGO Navigator and the Download Center. With its software solutions, WAGO is pursuing a strategy of interoperability. Its partnership with Bosch Rexroth and the associated integration of the crtIX OS operating system will allow even greater freedom for automation of medium- and high-performance-class controllers.

### **CODESYS V3**

The changeover from e!COCKPIT to CODESYS V3, the industry standard, now gives developers an established programming environment with the latest programming standards, tailored to the specific application in industrial environments throughout the entire product lifecycle. CODESYS V3 contains all the IEC 61131 engineering functions important for state-of-the-art automation. The manufacturer-independent engineering environment opens up new possibilities in conjunction with other systems.

### **WAGO Navigator and Download Center**

WAGO Navigator and the Download Center offer central access to all updates so you never miss another one and your software always stays up to date. The new Navigator provides updates for the CODESYS V3 engineering tools and the firmware. A direct interface to the Download Center makes the update process particularly easy. The new partnership with Bosch Rexroth allows even greater freedom for controller automation. WAGO uses crtIX OS, the manufacturer-independent operating system from Bosch Rexroth, for medium- and high-performance-class controllers.

Download  
Codesys here!



# Fieldbus-Independent and Modular

## The Right Controller and Fieldbus Coupler for Every Application



### Controllers 750

- Controllers for all common fieldbus systems and ETHERNET standards
- Quick commissioning
- Programmable via CODESYS 3 (IEC 61131-3)
- Directly connect to a wide range of I/O modules within the WAGO I/O System 750
- Use in a wide variety of applications and environments
- Tough enough for eXTReMe environments



### PFC Controllers

- High processing speed and a wide variety of interfaces
- Economical configuration via engineering software
  - **e!COCKPIT** (CODESYS V3)
- Scalable control technology protects your investment
- Real-time Linux® operating system
- High-level security with TLS, SSH, OpenVPN/IPsec and a firewall
- Send/receive data to/from the cloud via MQTT
- For eXTReMe environments too



### Compact Controller 100

- The new compact controller with integrated I/Os is perfect for smaller automation solutions.
- Controller with real-time Linux® operating system
- Compact controller with I/Os in a DIN-rail-mount enclosure
- Manufacturer-independent CODESYS V3 engineering environment



### Fieldbus Couplers

- Fieldbus couplers connect the WAGO I/O System 750 to a higher-level control system
- Fieldbus-independent – compatible with the most common fieldbus protocols and ETHERNET standards
- For eXTReMe environments too

# WAGO Hardware – Countless Software Options

The best way to implement various use cases rapidly is with an open source approach (no vendor lock-in). Our automation devices allow a wide variety of software to be used, giving you the fastest, best solution for your use case.

## Docker and WAGO – the Modular Approach to Automation

Virtualization with Docker or Kubernetes, for example, gives you the option of using additional software tools like Node-RED, InfluxDB, Grafana and many more besides the native PLC runtime in parallel on WAGO devices. The microservice architecture reduces hardware, costs and time for you.

**We connect hardware and software for you!**

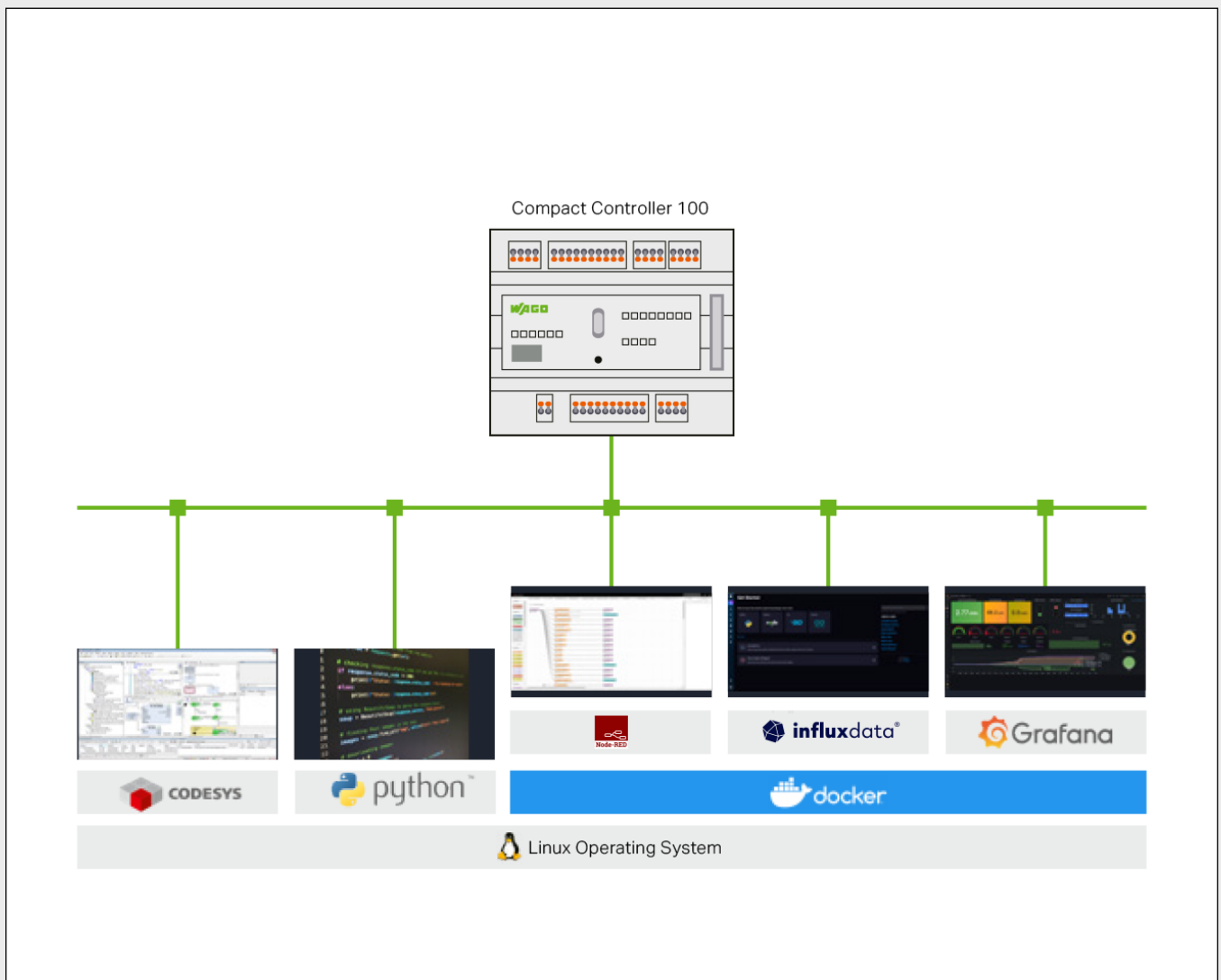

## WAGO and Portainer with Docker Swarm

We support the use of various open source tools, meaning no vendor lock-in:

- Various cluster options:  
e.g., Docker Swarm, Kubernetes, ...
- Different container orchestration tools:  
e.g., Portainer Server, OpenShift, Ansible, RedHat ...
- Easy onboarding of new hardware in the cluster

- Remote device management: e.g., Portainer Agent, Jfrog Connect ...
- Full-fledged maintenance and commissioning solutions, such as firmware updates, application rollout, secure and roll-forward/roll-backward strategies, can be executed quickly and easily

**We connect cloud and on-premises solutions for you!**

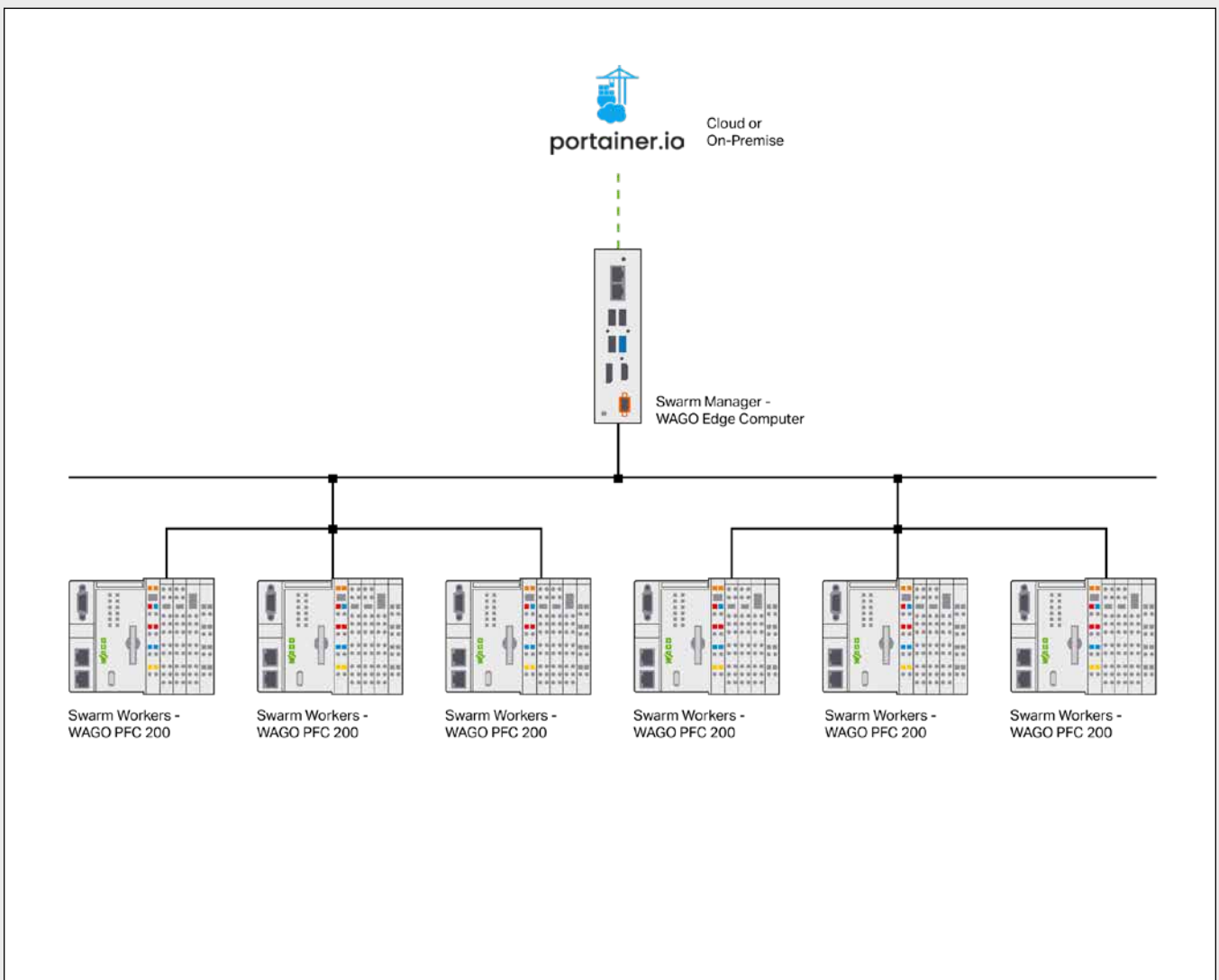

# Device and Application Management

## Manage over 1000 Devices from One Point

### Kubernetes Implementation

WAGO devices support the tool of your choice and meet all your requirements, from the IT department to the shop floor. We support all common bus protocols e.g., OPC UA, MQTT, EtherNet/IP, Profinet, EtherCAT, etc. The integration of legacy equipment and third party devices gives you complete flexibility and future-proofness.

Thousands of devices can be managed easily from a central location with minimal effort.

### The Benefits for You:

- Open hardware architecture
- Easily scalable – even small solutions are possible
- Cost-effective and efficient – an economical solution
- Firmware security and application updates can be scheduled for all devices at the same time
- Secure, automatic provisioning for new devices
- Easy provisioning and deprovisioning for all devices (new or end-of-life management)

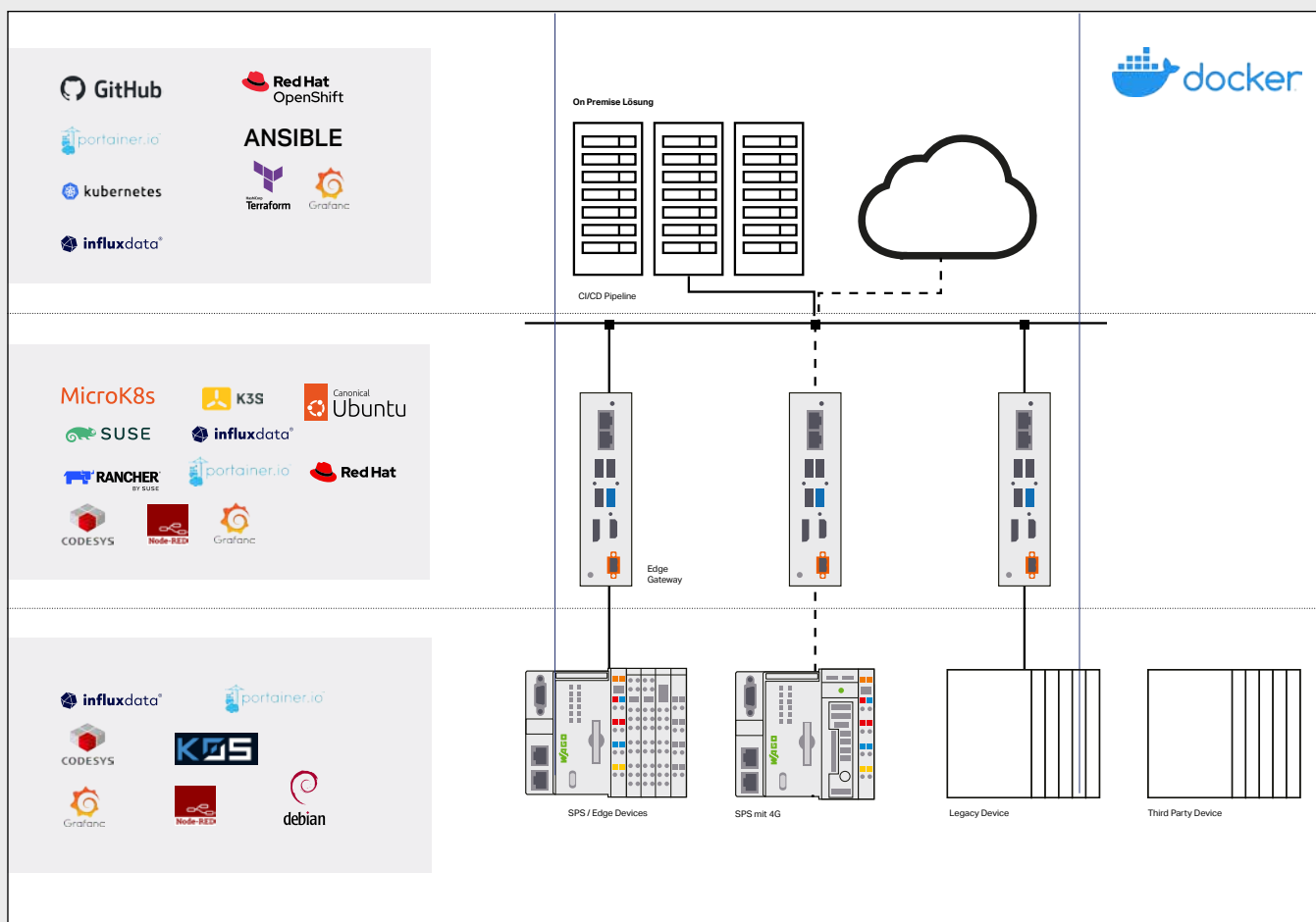



# Connecting Existing Controllers to the IoT Infrastructure

## Connecting IoT and IIoT

WAGO devices support all standard bus protocols, e.g., OPC UA, MQTT, EtherNet/IP, Profinet, EtherCAT, etc. This allows you to connect your existing systems to your IoT infrastructure quickly and cost-effectively.

No matter which existing controllers you use – we connect you to the IoT infrastructure.

- Preventive maintenance
- AI connection of existing systems
- Production process optimization

**We Connect IIoT and IoT for You!**

## Check Out Our Software Projects

GitHub



Docker



WAGO | Open Source Forum

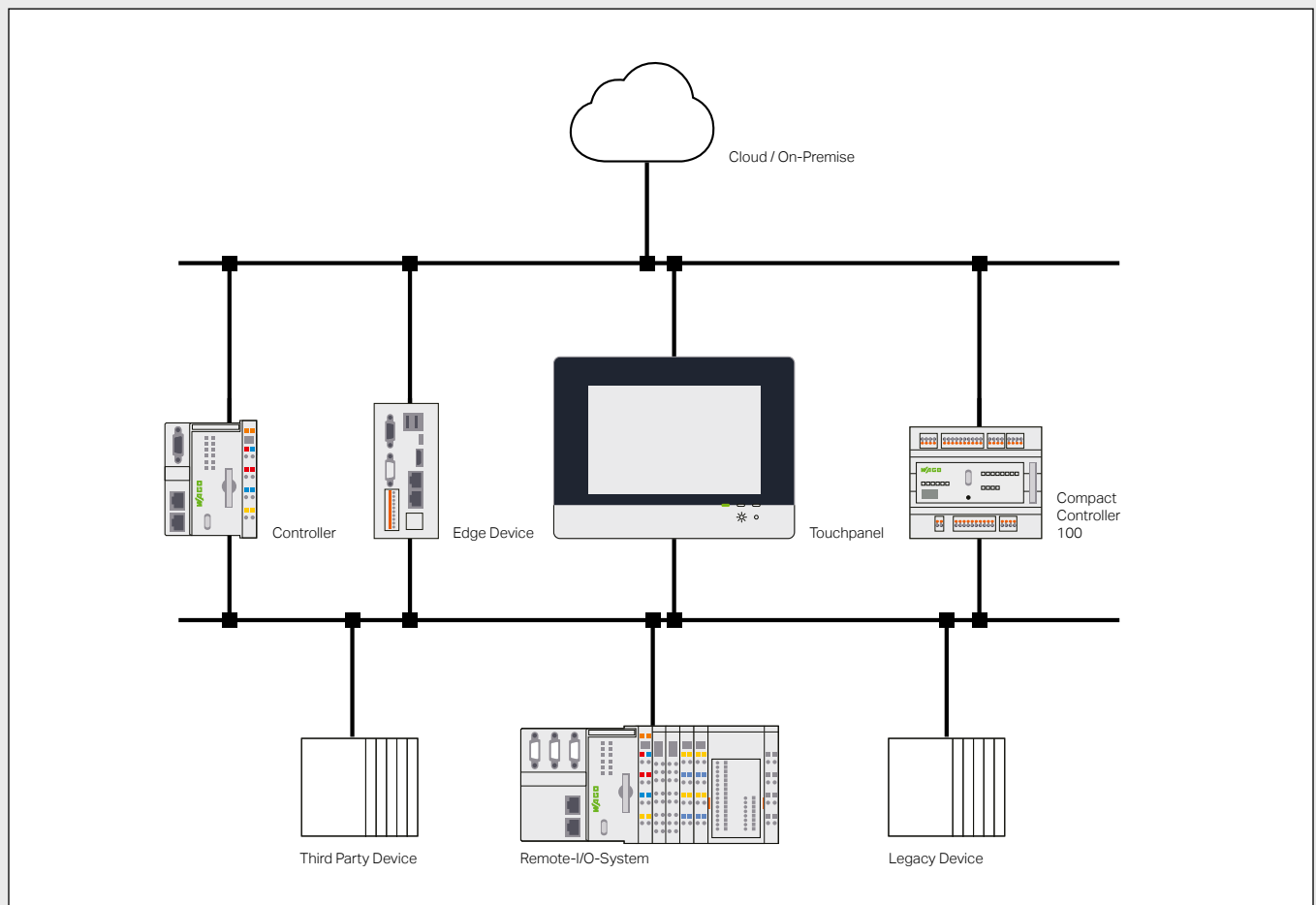

# The Stamping Plant

## Stable Processes with High-Performance Components from WAGO

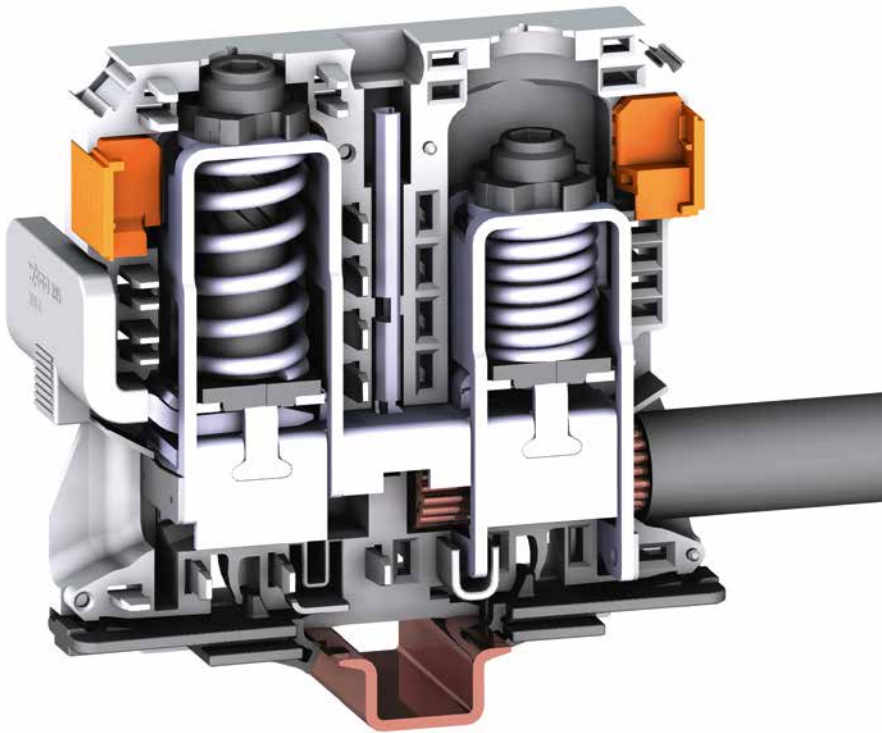

In a stamping plant, finished body parts are constructed in various steps. From these flat metal strips, stamping creates sheets and small plates with rectangular, trapezoidal or other special geometric shapes.

Springs or robots insert these plates into the individual work steps, and they are then passed on to the following process. Mechanical or hydraulic presses use high pressure to shape the plates in three dimensions.

## Optimal Clamping Force up to 185 mm<sup>2</sup> (350 kcmil)

### High-Current Rail-Mount Terminal Blocks with POWER CAGE CLAMP

Springs instead of screws is the WAGO way – the POWER CAGE CLAMP provides optimal contact force with conductor cross-sections of 35, 50, 95 and 185 mm<sup>2</sup>.

WAGO's high-current rail-mount terminal blocks meet the most stringent requirements. They withstand heat and cold even under the heaviest of loads. The terminal blocks can be wired quickly, eliminating time-consuming preparation with ring terminals or ferrules. They offer the perfect clamping force, independent of the user's skill level.

In short, they are:

**Vibration-proof, fast and maintenance-free!**

When power taps are used, even smaller conductors can be connected effortlessly. Accessories such as jumpers, warning covers, test adapters, continuous marking strips and WMB markers, are also available.



# Energy Supply and Distribution

Reliable and Flexible: WAGO TOPJOB® S Rail-Mount Terminal Blocks with Push-in CAGE CLAMP®

## The Benefits for You:

- Three actuation variants: lever, push-button and operating slot
- Comprehensive marking options
- One existing range of TOPJOB® S jumpers for all three variants
- Push-in connection technology: direct termination of solid and fine-stranded conductors with ferrules for all variants
- Test options for all variants
- Covers all conductor cross-sections from 0.14 to 25 mm<sup>2</sup> (24–4 AWG)

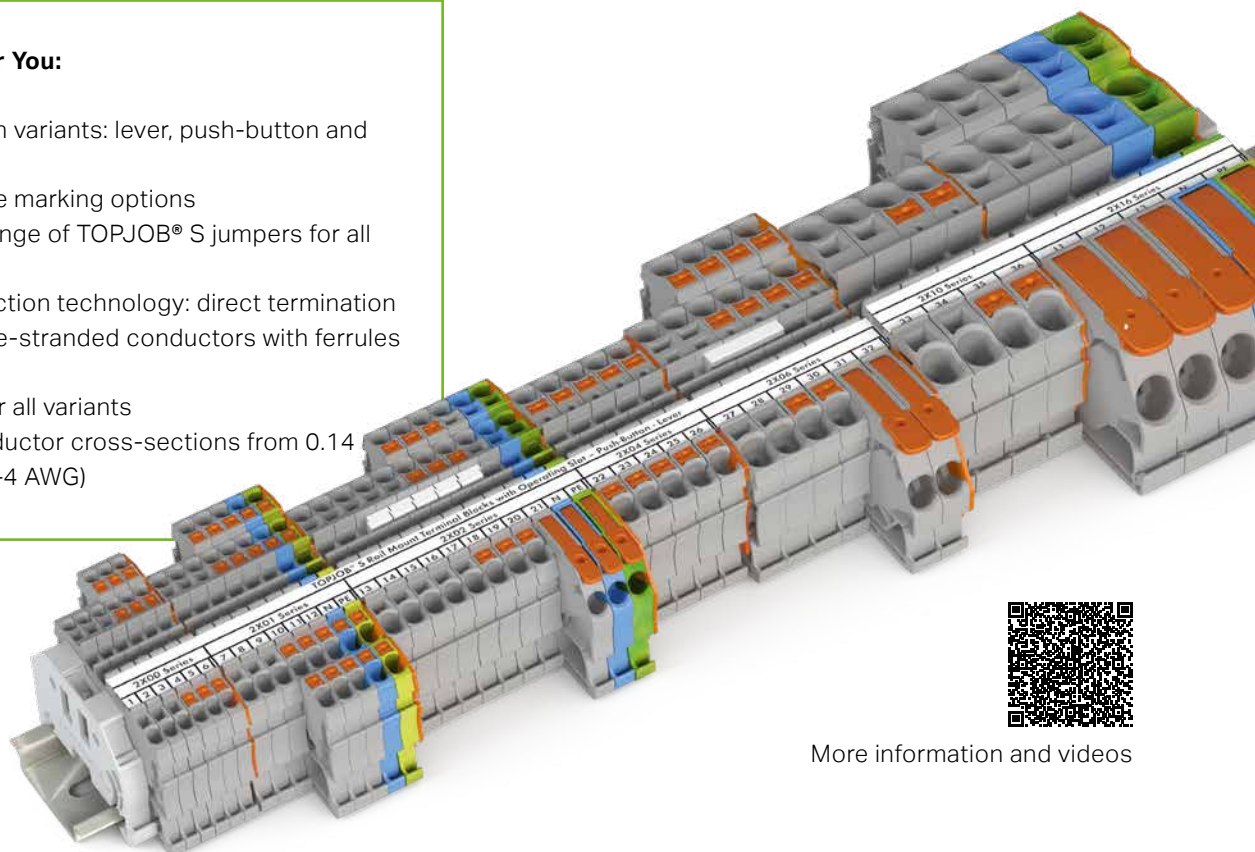

More information and videos

# Energy Data Acquisition with WAGO

## The Right Solution for Every Step

Our solution for your energy data: Record and visualize your measurement data for different media and parameters in no time. Continuous recording and monitoring provide the basis for reducing energy use and conserving resources – and ensure compliance with the DIN EN 50001 standard for energy evaluation.

WAGO Energy Data Management consists of Web-based application software combined with a modular, open, flexible control system you can install and expand easily – whether you're looking for a custom solution or prefer to use our standard solution. Our system records measurement data for different media and parameters for energy monitoring and processes them for further analysis, archiving and reporting.

The software automatically detects different signals from the connected meters and sensors, making them available to additional energy analysis tools via simple parameter settings. This information guides you in optimizing energy consumption in your building or production facility – whether your sites are clustered locally or distributed all around the world. Are you just getting started with energy management, or are you ready to delve in and identify further potential savings?

**WAGO has the right solution for you.**

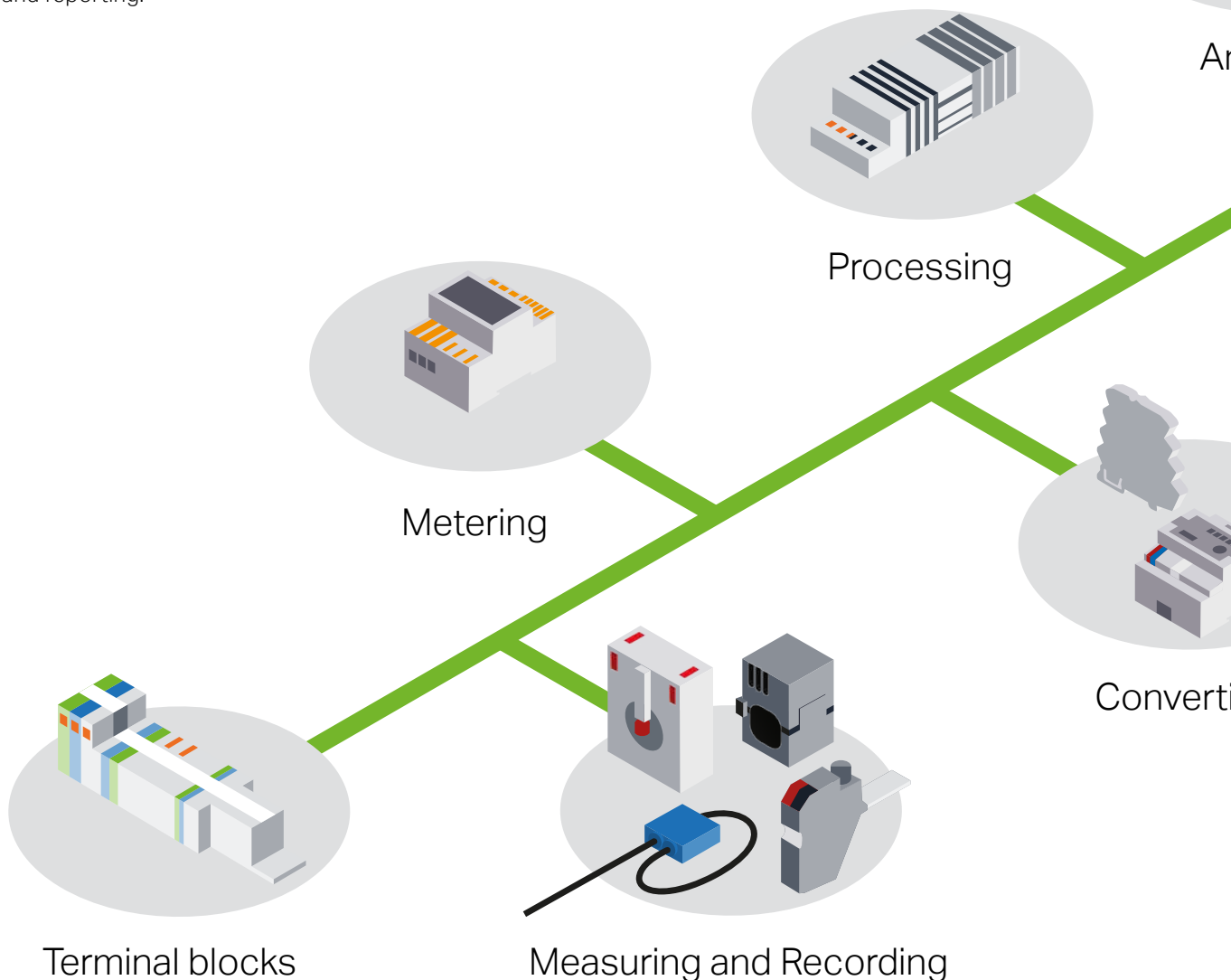

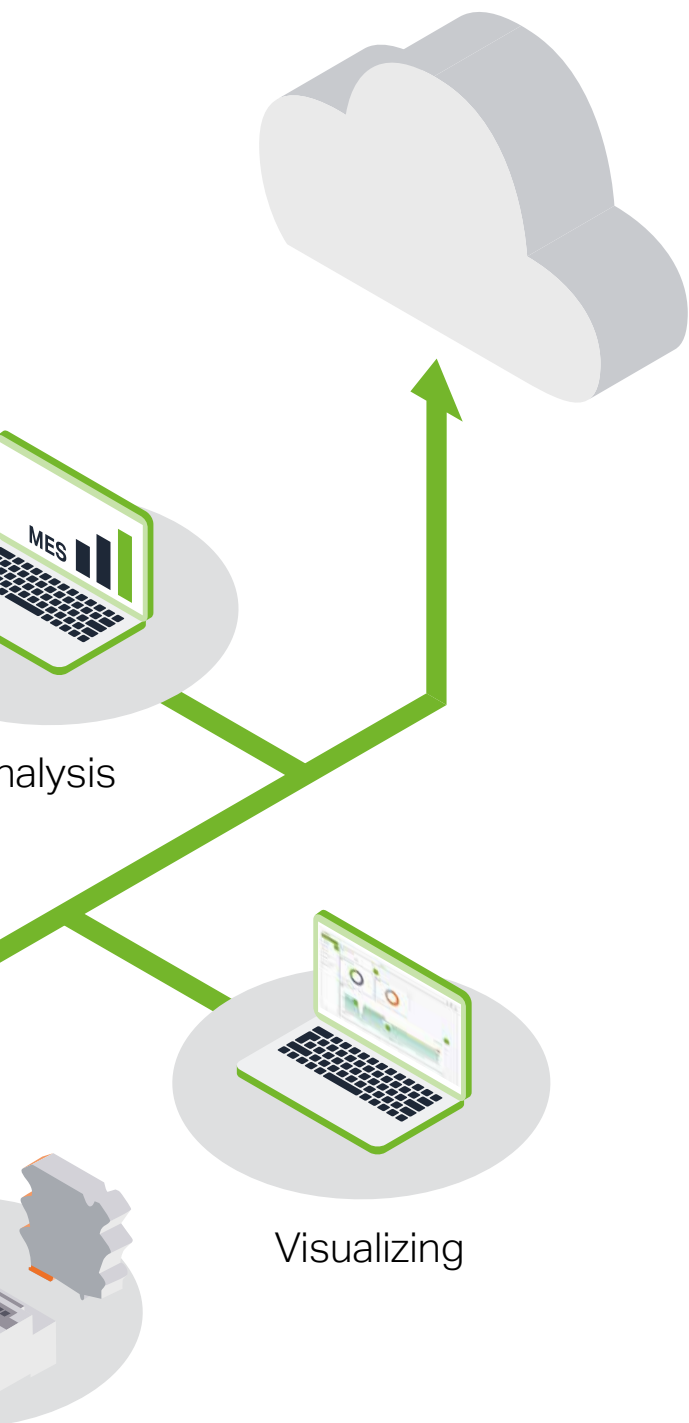

**Our contribution to your energy efficiency:**

- A wide portfolio of products for measuring, recording, metering and converting your energy values
- Ready to use: With our IoT Box Energy Data, you can get started right away
- We work together to develop and implement solutions that meet your individual requirements

**Measuring and Recording**

WAGO offers suitable products for both new and existing systems in your specific application area.

**Metering**

Optimizing energy consumption requires comprehensive energy measurement. WAGO's portfolio has energy meters that simplify this task while offering several key advantages. The 879 Series Energy Meters measure the energy supplied or consumed through the MID declaration of conformity, even in billing-relevant applications.

**Converting**

Measured variables, whether current, voltage or power, need to be converted and filtered for higher-level controllers. WAGO signal conditioners allow them to be transferred as standardized signals or via bus communication.

**Processing**

Once recorded, the measured variables need to be processed. That's where WAGO's Energy Data Management comes in.

**Visualizing**

Create your own personal dashboard and see efficiency trends presented in a clear, comprehensible, device-independent way.

**Analyzing**

Our wide range of interfaces and protocols ensures easy connection to higher-level energy management systems.

**The Benefits for You:**

- Ready to go in just a few steps
- No programming experience required
- Integrated cloud connectivity



More Information

# The Body Shop

## High-Performance Automation for High System Uptime

After being shaped in the stamping plants, the sheet metal parts undergo additional processing in the body shop. The body shells are assembled by gluing, welding or press-joining techniques that use highly automated equipment and stationary industrial robots. Producing a body shell demands maximum system availability, precision and protection of humans and machines.

One of the greatest challenges in the body shop manufacturing a huge variety of vehicle bodies according to the highest product quality demands, making high-performance automation essential.

The goal is maximum system uptime with a minimum product error rate. To achieve this, system parts from different manufacturers need to fit seamlessly into the automated production process in order to achieve the 90 % level of automation that has become the norm.

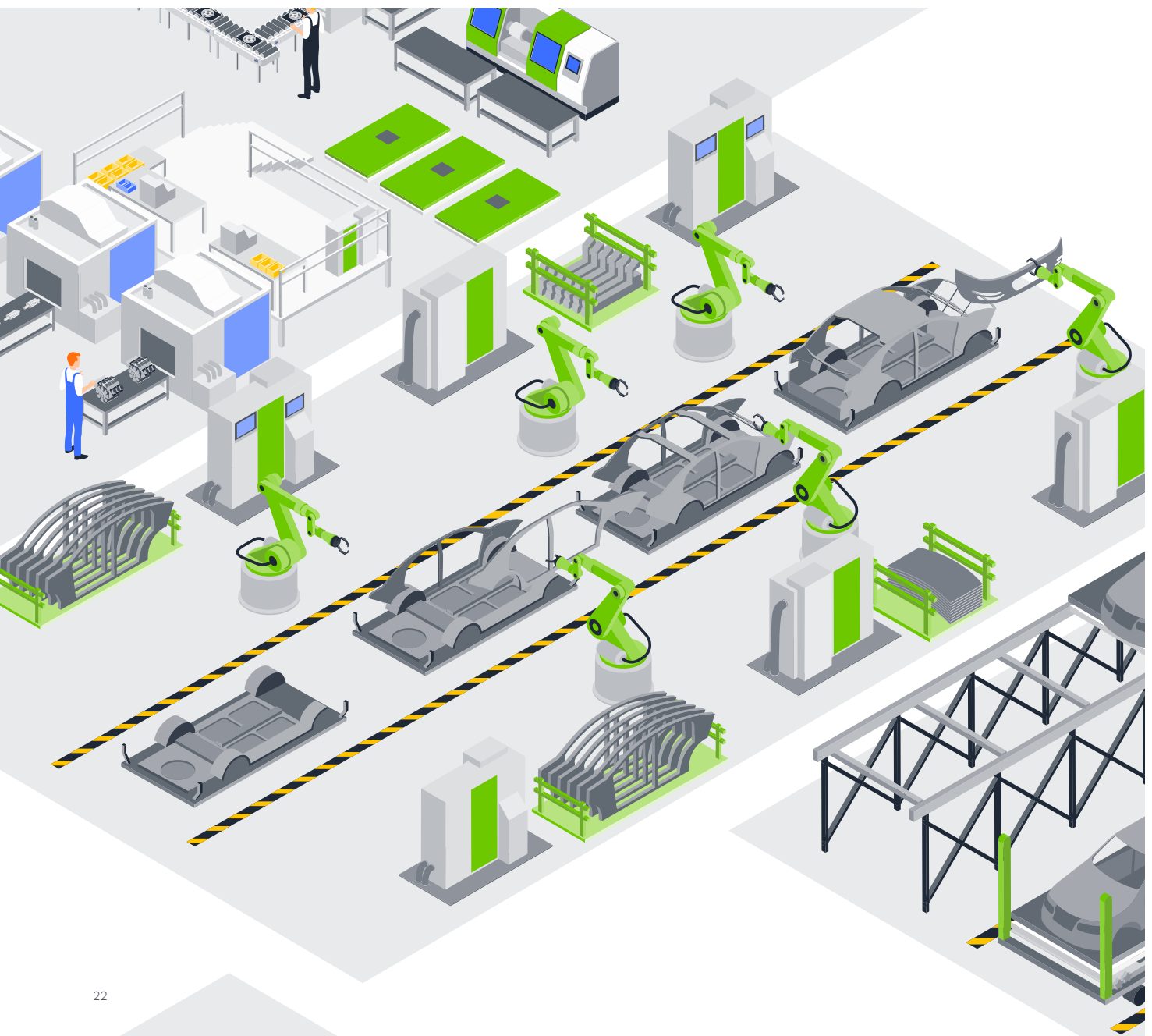

# Control Panels

Operating and display devices in the “Control Panel” software configuration allow simultaneous control and visualization, providing a very compact automation solution. Through use of a dedicated library, these panels become IoT controllers that send data from the field level to the cloud. Once in the cloud, this data can be aggregated and used for analysis. This capability creates tremendous added value for your company – whether for increasing the efficiency of in-house production, implementing energy management in buildings or developing additional end-customer services. This also makes existing systems IoT-ready and future-proof.



## The Benefits for You:

- Control and visualization in one device
- Docker container support
- Integrated Web and Visu Panel functionality
- Supported fieldbus protocols: Modbus TCP, CANopen, EtherNet/IP adapter
- Optional EtherCAT® master
- IoT-ready (MQTT) and OPC UA

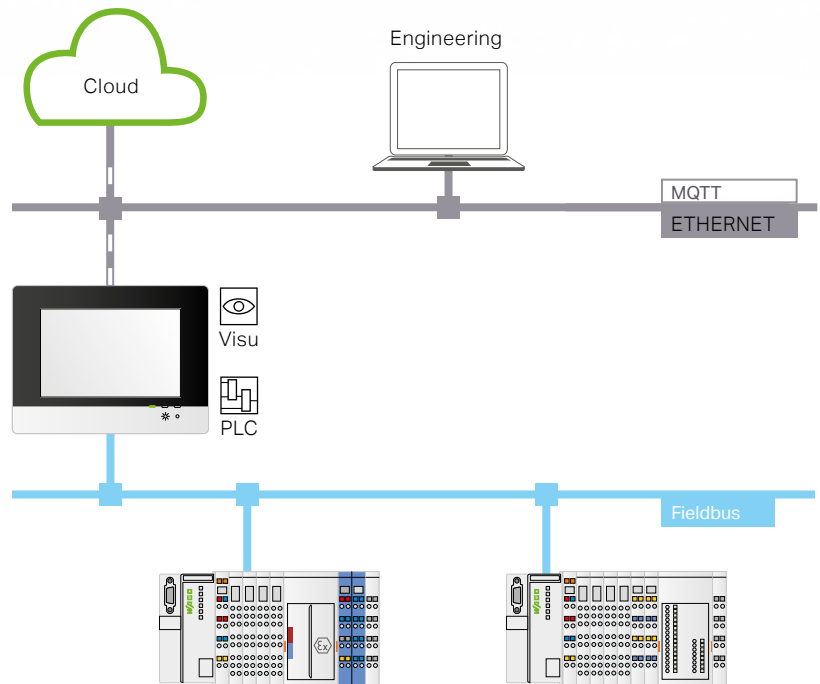

More information and video



# The WAGO I/O System Field, IP67

## Functionality and Aesthetics in One System

### The IP67 I/O System Field is perfectly suited to meeting the demands of automotive manufacturing.

The IP67 I/O System Field offers uncompromising protection with zinc die-cast housings for extremely harsh environments, or robust yet lightweight plastic housings for mobile applications, making it perfect for use in body shops.

### The IP67 I/O System Field holds up to welding sparks and high vibrations.

The modules operate reliably at temperatures from  $-25$  to  $+70^{\circ}\text{C}$  ( $-13 \dots +158^{\circ}\text{F}$ ) and, thanks to internal shielding, are immune to electromagnetic interference. Even high-temperature applications in paint shops are no problem for the IP67 I/O System Field. Therefore, the modules can be mounted perfectly where you need them: right where your sensors and actuators are installed. This not only reduces cabling, but also minimizes the time and effort required for commissioning, service and diagnostics.

### Slim housing variants and lateral mounting options offer even more freedom for the ideal installation.

With the IP67 I/O System Field, you're ready for the future. In addition to all standard fieldbus protocols like PROFINET, Ethernet/IP and EtherCAT®, it also supports additional future-proof protocols. Particularly salient examples include MQTT for direct connection to future cloud systems or OPC UA. The modules' entire power supply is provided through the new M12 version with L-coding, giving you up to 16 A power at your modules and greater flexibility in distributing their duties.



More information and videos







**Rugged resistance** to the harshest environmental conditions (like those found in metal-working centers prone to impact, vibration, oil, grease, water or dust) thanks to the encapsulated electronics in the metal housing



**Highly dynamic** for robotics and material handling equipment thanks to lightweight plastic housings



**Flexible machine-mounting** thanks to various mounting options and a compact design (no adapter, oblong slots for lateral mounting); simple module mounting on T-nut profiles with machine screws and T-nuts requires no drilling; this expedites installation during commissioning and makes replacement faster.



#### **Space-saving ergonomic design**

User-specific marking with WMB Inline from the WAGO marking program; ergonomic LED positioning for high visibility despite the presence of cables and connectors; on-device factory markings are easy to understand. Sensors and actuators are connected via standard M8 and M12 connectors.

The M12 L-coded power supply version offers up to 16 A for more power in less space.

#### **The Benefits for You:**

- One series for all your applications
- The modules' diagnostic capabilities make commissioning and maintenance easier
- Future-proof thank to cloud and OPC UA connections
- Fully encapsulated IP67 metal housings for extreme environments
- Lightweight IP67 plastic housings for mobile applications
- Reduced downtimes thanks to detailed identification, convenient marking options and clearly visible LEDs

# The Structure of the WAGO IP67 System Field

Usable for:



IP67

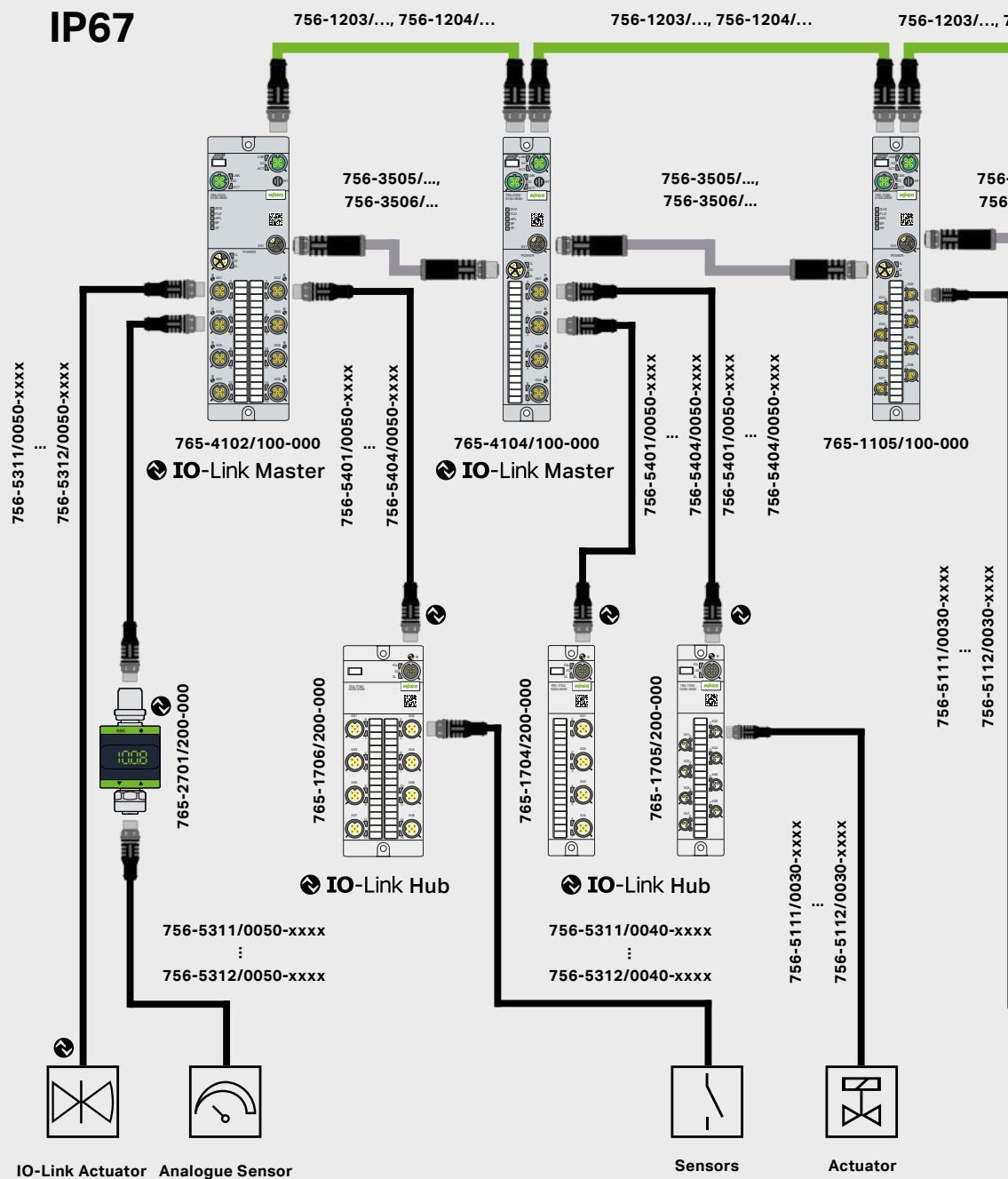

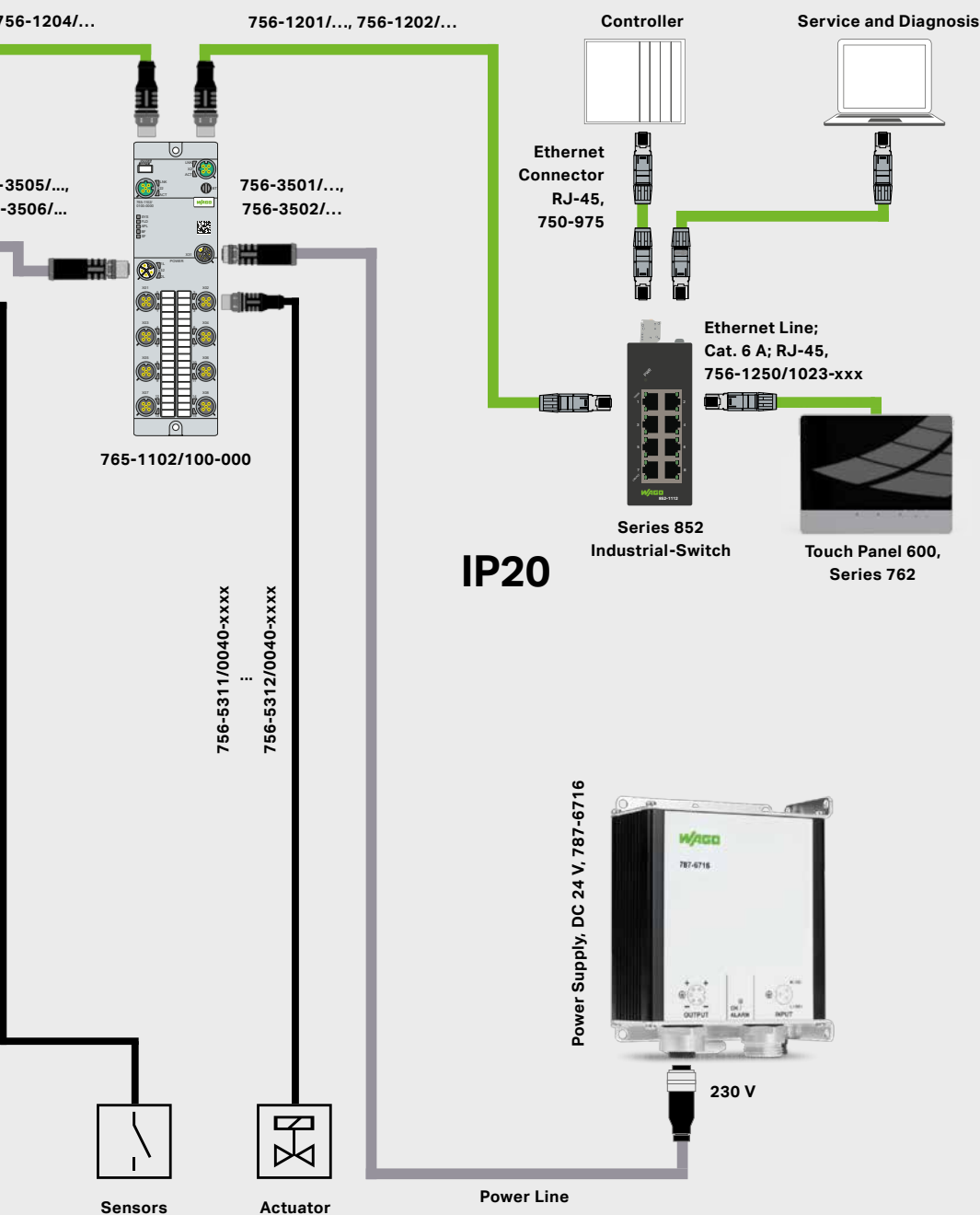

I/O System Field

IP67

# Extended Network Connectivity

**Modern, decentralized production systems require automation solutions that ensure the highest level of connectivity and provide maximum performance outside the control cabinet.**

WAGO developed its upgradable I/O System Field with IP67 protection to meet these needs today and tomorrow. It combines fast ETHERNET-based fieldbuses like PROFINET and technologies like OPC UA, *Bluetooth*® and Webserver, as well as MQTT for cloud connectivity.

## Made for TSN

Industrial Ethernet and PROFINET on the field level provide the basis for digitization with WAGO I/O System Field. EtherNet/IP and EtherCAT® are planned in as ETHERNET-based standards; in the future, the I/O System Field will also support TSN (Time-Sensitive Networking).

## MQTT

The WAGO I/O System Field supports MQTT as an open message protocol for data transmission.

## OPC UA

The system is equipped with an OPC UA server, allowing OPC UA clients to access a huge range of device data, such as parameter data, status information, identification/diagnostics data and containers.

## IO-Link

Fieldbus modules equipped with IO-Link masters and IO-Link hubs as devices facilitate effective, versatile connection of intelligent sensors/actuators to the automation system.

## Bluetooth®

For wireless access via mobile device, an app is available that provides direct access to a WAGO Field device by identifying a data matrix code and communicating via BLE (*Bluetooth*® low energy).

## HTTP/HTTPS

An integrated Webserver enables HTTP and HTTPS communication. With this capability, a wide range of system information can be accessed through standard browsers.

## Analog IO-Link Converter

Integrate Analog Signals via IO-Link

The new Analog IO-Link Converters for the WAGO I/O System Field provide an economical, compact solution for easily integrating conventional analog sensors and actuators into an IO-Link system. This also allows retrofit projects to be integrated into digital communication. With the new Analog

IO-Link Converter, you have a cost-effective, interference-free option for analog value transmission. On variants equipped with displays, the parameters can also be set directly on the device.

A compact design, IP67 protection and a high operating temperature range make the Analog IO-Link Converter (U, I, RTD) ideal for automation without control cabinets.

### The Benefits for You:

- Easy conversion of analog signals with IO-Link
- Interference-free signal transmission
- Compact design with IP67 protection
- Ideal for retrofit projects



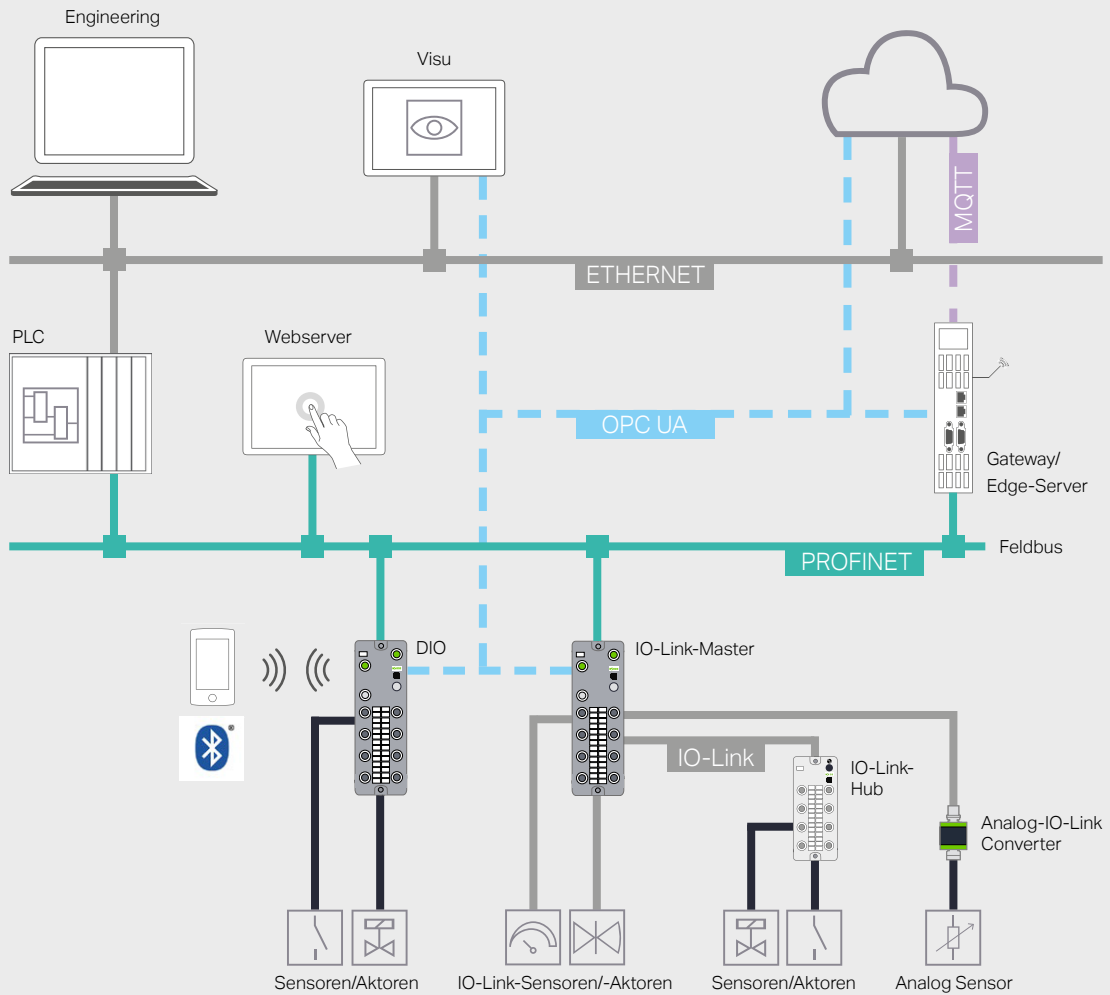

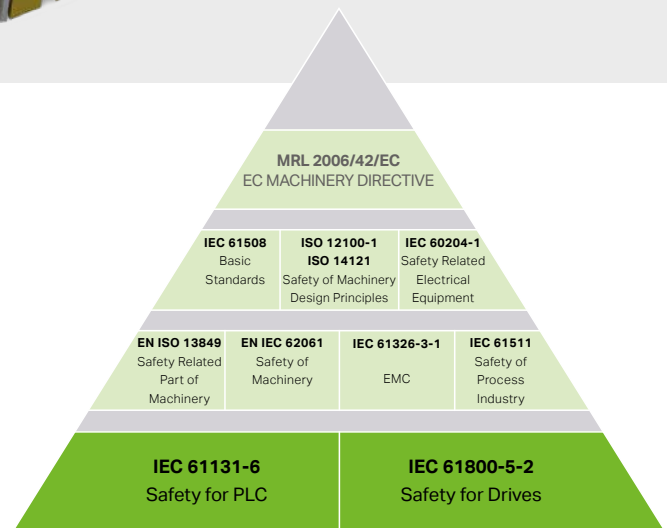
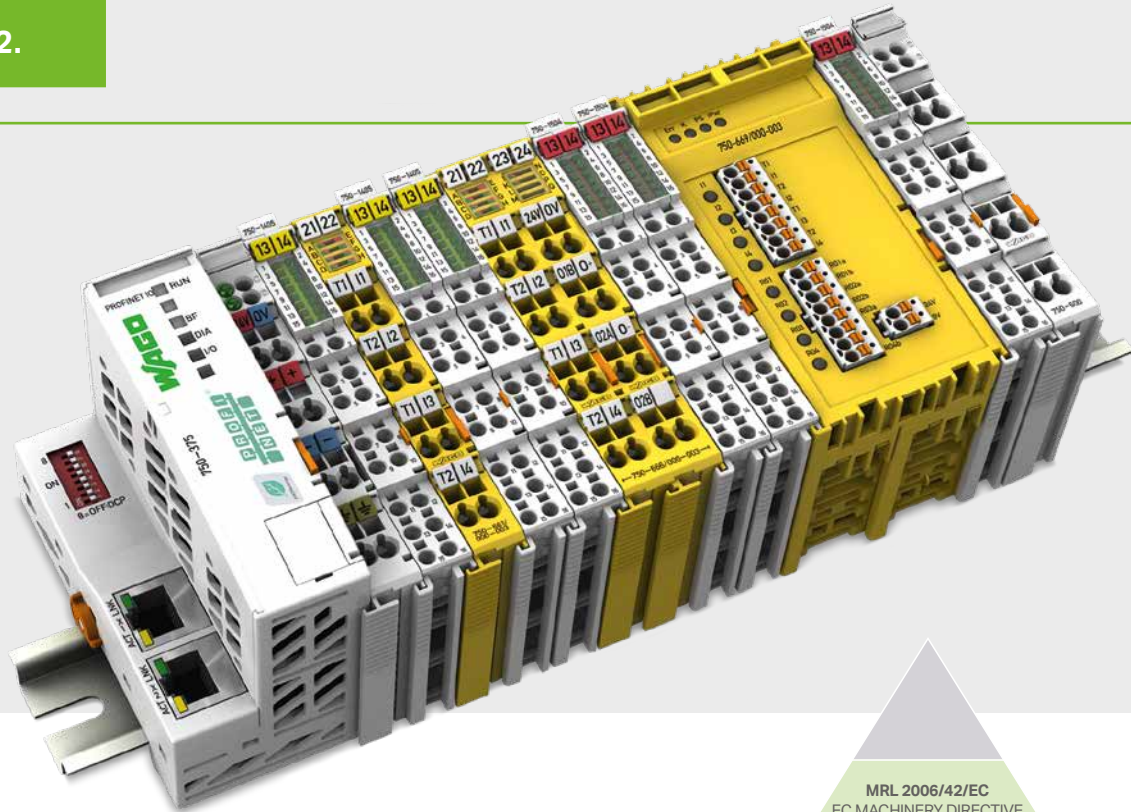

## Safety First

### Easy Connection to the Failsafe PLC

In the European Union, the machinery directive sets the requirements for machine and system safety. It provides a uniform standard for “life and limb” protection of workers within a machine’s operating area.

The required risk assessment is based on harmonized standards (e.g., EN 13849) and identifies existing risks and the required risk reduction (SIL or PL quality). Based on the risk assessment, safety functions can be implemented, for example through presence detection or protection zone violation detection, using secure switches or light arrays to shut down the “risk” immediately.

For this purpose, the safety signals are detected by the “yellow” safety modules and transmitted via “PROFIsafe” to the fail-safe PLC for additional processing. The result is then executed via safe actuator (output module, controller etc.).

The unique safety characteristics of the WAGO modules facilitate calculation of the final safety function up to Cat. 4/PLe per EN 13849, or SIL3 per EN 62061 or IEC 61511.



# Seamless Integration of Field Devices

## Tool Calling Interface (TCI) and iPar Server

By their very nature, complex manufacturing processes require integration of a wide variety of field devices from different manufacturers. With the definition of the TCI and iPar Server system services, the PROFIBUS User Organization e. V. (PNO) has provided the basis for integrating different field devices. Our graphs show examples of WAGO I/O System integration in terms of functional safety using the WAGO-I/O-PROFIsafe-V2-iPar modules.



More information  
on functional safety:

### The Benefits for You:

- Standardized interface for calling manufacturing tools
- Communication with the device via fieldbus through an interface
- Transfer of device and topology information
- Data backup in the project directory

### The Benefits for You:

- Reliable recovery of module parameterization
- Module replacement without tooling
- Replacement requires no special qualifications
- Optimized WAGO solution available



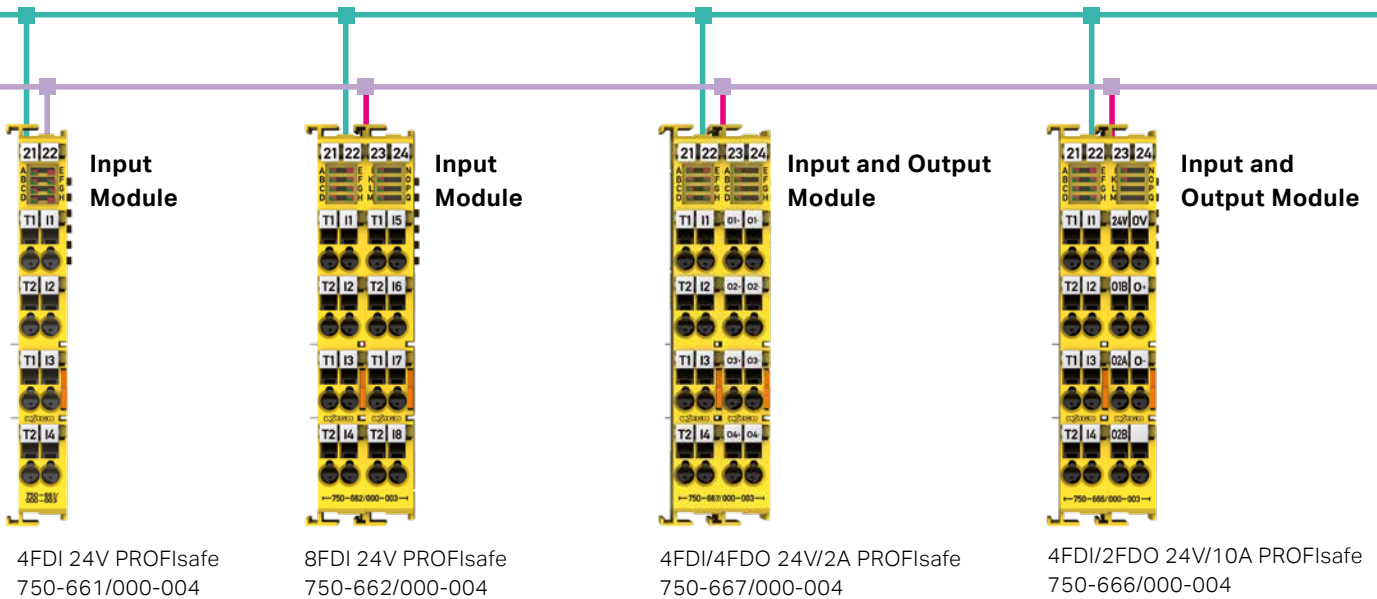

## Parameterizable Functions

### Digital Inputs

- Input filter time
- Signal preprocessing
  - Valence/antivalence
  - Discrepancy time
  - Restart lock
  - Mode selector

### Digital Outputs

- Test pulse length
  - Dark/light test
- Line break detection
- Active discharge

### Analog Inputs

- Internal/external/automatic acknowledgement
- Passivation for each channel/module
- Analog value formats (e.g., RIOforPA)
- Sampling frequency
- Line break detection
- Mean calculation
- Substitute value

## Extensive Diagnostics

### LED Display

- Status for each channel
- Active diagnostics
- PROFI-safe status
- Parameterization status

### Fieldbus

- Standard PROFIBUS® and PROFINET® diagnostics
- Undervoltage
- Overload
- Short circuit – external voltage/GND
- Temperature
- Line break
- Measurement range error
- Parameterization error
- Signal preprocessing

### 4th Generation Behavior in the Event of an Error

- Module error – module passivation
- Channel error – passivation for each channel

## Offline Parameterization via GSD in PROFINET®

Offline parameterization allows you to parameterize your safety modules using the device description in PROFINET®. With this, you can easily create your safety application offline and duplicate it on similar machines. When the application restarts, the offline parameters automatically transfer to the modules. This makes device replacement possible at any time, even without tooling!





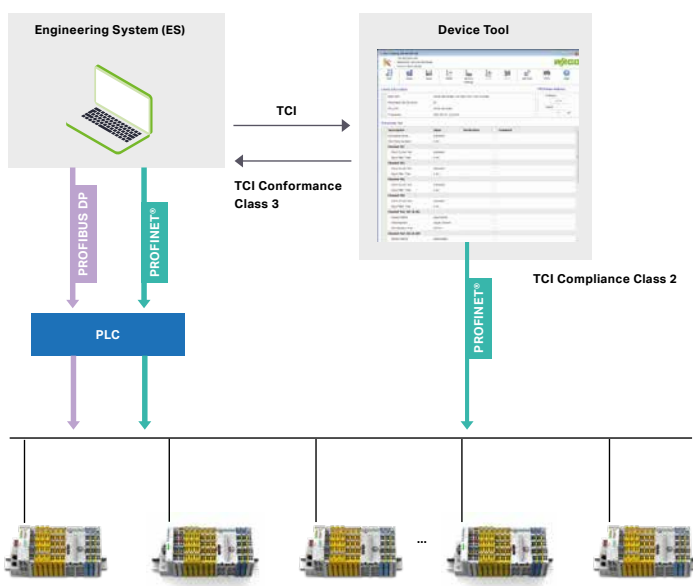
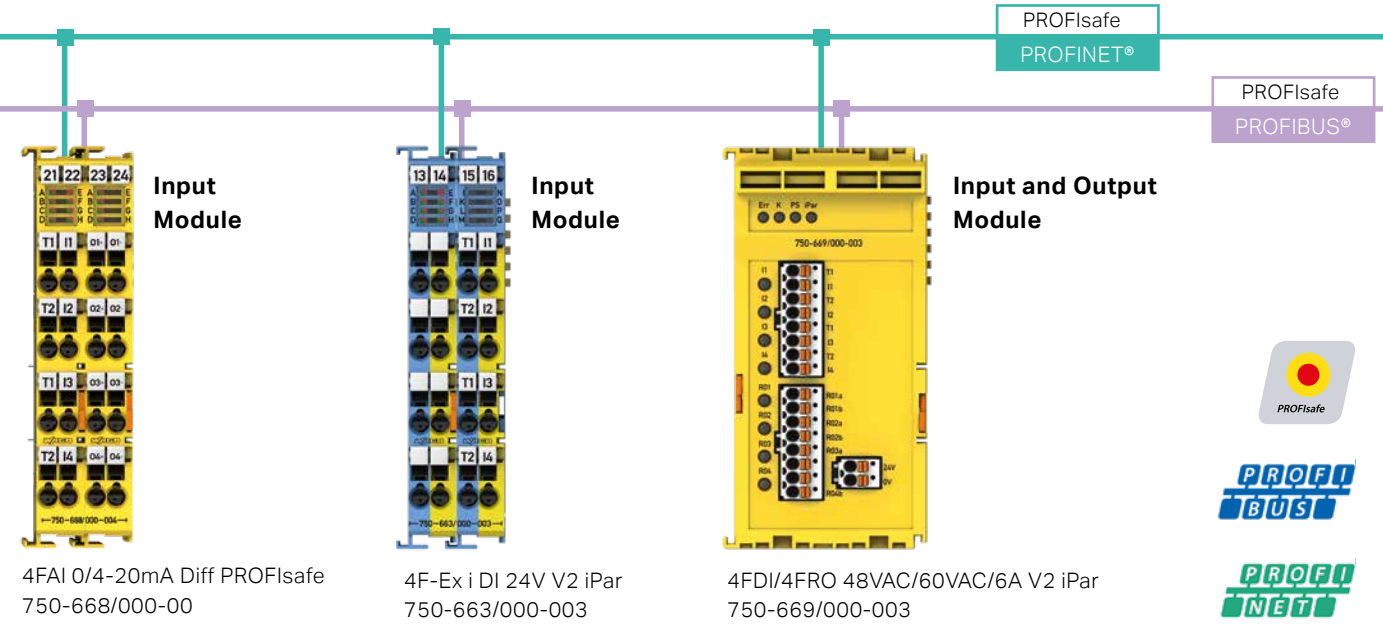

**Easy Configuration via Tool Calling Interface (TCI)**  
 The Tool Calling Interface (TCI) is a standard interface of the PROFIBUS® and PROFINET® user organizations. It provides direct access to the product's parameterization from the engineering system. TCI also allows an existing control system's communication structures to be used.

**Functional Safety and Easy Integration**

iPar server technology support – module replacement without tooling

1. iParameter download – restore module parameters after module replacement or initial commissioning
2. iParameter upload – store and back up parameters in the application program

iPar CRC in the module protects the parameters.

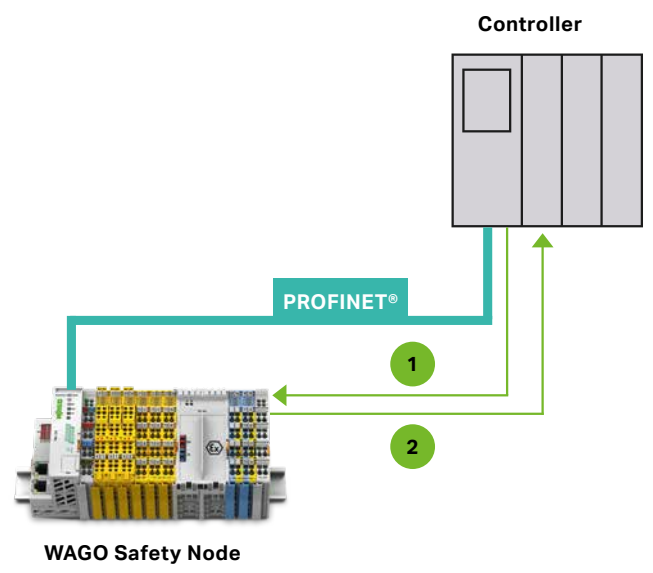

# The Paint Line

## Perfect Surfaces through Seamless Processes

An automotive paint line consists of multiple different steps. For a smooth workflow and a perfect paint finish, a continuous supply of the required paints and marking materials is a must.

Many paint shops typically contain hazardous areas in some locations, and these require corresponding protective measures. The WAGO I/O System 750 is ideal for exchanging signals between the PLC and the field level. The blue intrinsically safe Ex i modules can be easily integrated into a standard I/O node. This enables direct connection of sensors and actuators from Zones 0/20 and 1/21. Even safety connections, which are otherwise so difficult, can be made directly in and out of the Ex-i area.

### The Benefits for You:

- Eliminating the Ex barrier saves money
- Combined nodes: integration of blue Ex i modules and yellow safety modules into a standard I/O node
- Silicone-free products

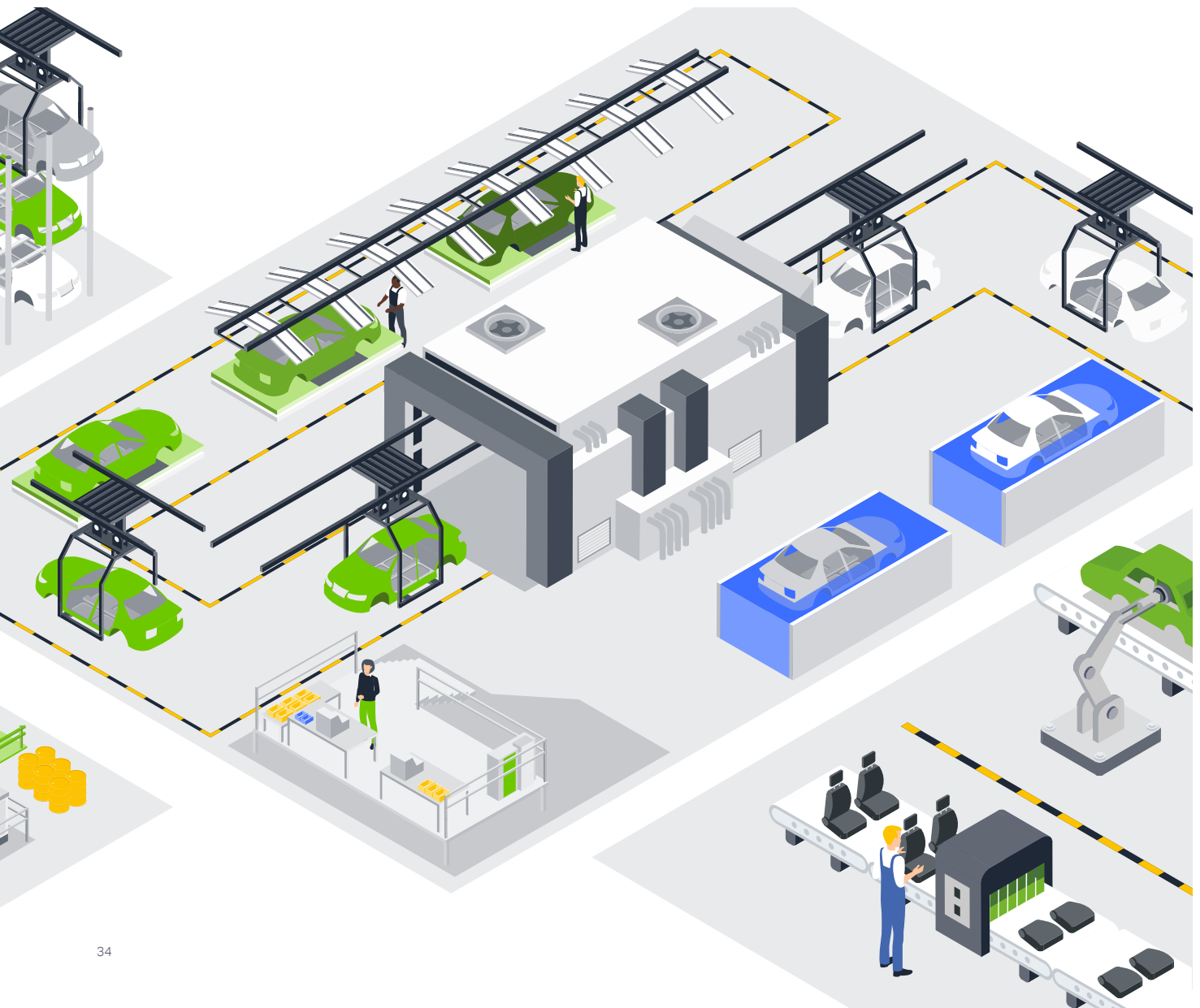

# Vibration Measurement

To ensure a consistent surface quality on a painted car body, it is important to keep air conditions within the paint booth constant. What is the best way to achieve this? As a general rule, the air conditions are controlled via multiple fan motors. These are often in continuous operation, which places significant stress on them. In addition, the motors' running characteristics change throughout their product lifecycle due to aging. These changes in the motors always change the air conditions in the paint booth, which has to be avoided. One possible solution is so-called vibration measurement. Vibration sensors are installed on the supply air motors, which can detect changes in the vibration early on and signal the need for prompt maintenance. This prevents unplanned downtime and quality losses in the paint shop and optimizes the entire process. Until now, however, it has been quite costly

to use the vibration sensors for preventive maintenance measures and analysis purposes; since the data was usually stored in a controller, processing it further or making available to cloud systems required significant time and effort. Thanks to the WAGO I/O System Field, IO-Link-capable vibration sensors can be connected to the cloud quickly and easily, which makes simple analysis, evaluation and graphical representation feasible. The WAGO IO Field automatically converts the IO-Link signals to cloud protocols, such as OPC UA or MQTT, so you can process all your sensor data without further ado. In addition, all sensor data of the local PLC can be made available using standard bus protocols (Profinet, EtherNet/IP and EtherCAT).

## The Benefits for You:

- Direct connection of sensor data to the cloud enables fast installation and saves money
- Ideal for retrofitting for preventive maintenance – thanks to parallel communication of important sensor data between the PLC & cloud
- The ideal cloud coupler for future IoT applications
- Early detection of anomalies allows preventive maintenance
- Prevents unplanned downtime and quality losses
- Quick and easy retrofitting in existing systems thanks to the WAGO I/O System Field

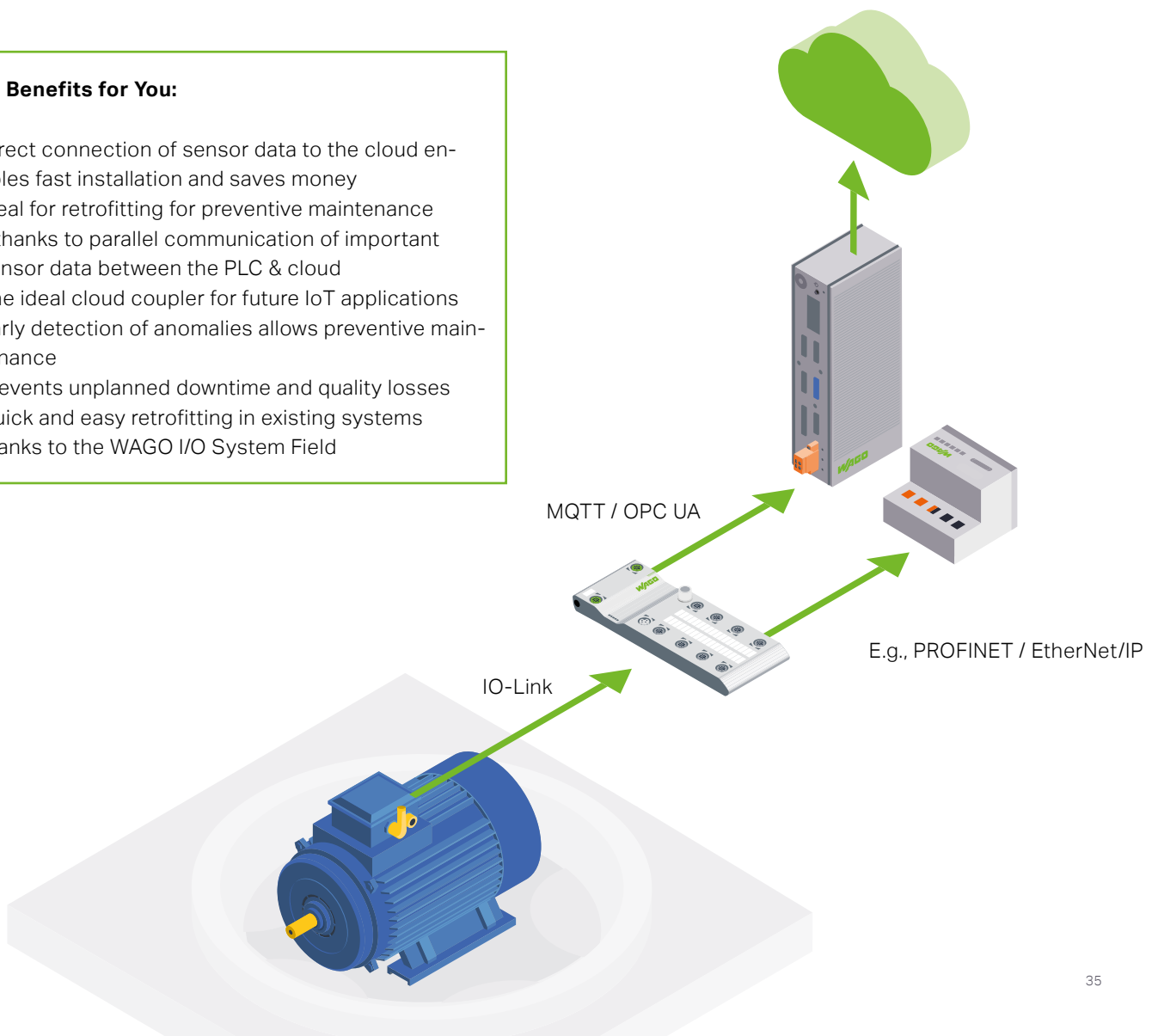

# Explosion Protection – Made by WAGO

## The WAGO I/O System 750

Whether offshore or onshore, above or below ground, in the refinery or producing pharmaceuticals and food – WAGO offers a universal system for your individual explosion-proof applications.

- Approved for use in Zone 2/22 hazardous areas for integration of intrinsically safe signals from the field up to Zone 0/20 and M1, M2
- Comprehensive certification, including ATEX, IECEx, ANSI/ISA, INMETRO etc., ensures worldwide use
- Intrinsically safe inputs with functional safety
- Rated up to SIL 3, Cat. 4/PL e PROFIsafe

## Relays and Signal Conditioners, 857/859 Series

Our relay modules and signal conditioners can be used in locations subject to gas explosions. They are just 6 mm wide, making them ideal for galvanic isolation of digital and analog signals.

- Simple configuration via easy-to-use DIP switches and software
- Vibration-proof connection technology – jumpers with Push-in CAGE CLAMP® connection minimize wiring

\* The exact special mounting requirements can be found in the product documentation.

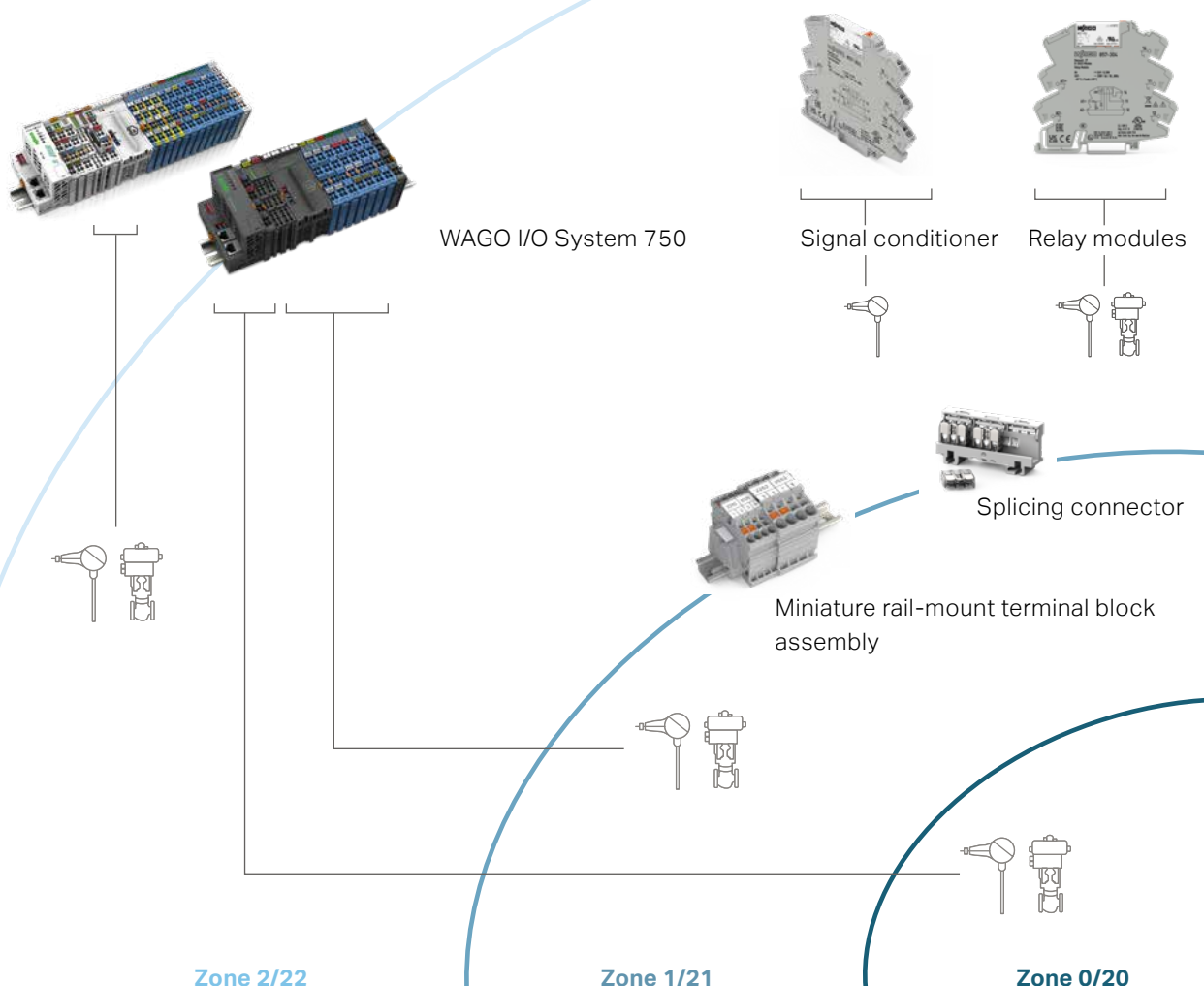

## TOPJOB® S and POWER CAGE CLAMP

Process engineering systems, such as pumps, compressors or drives are prone to both high- and low-frequency vibrations. Electrical connections are also often subjected to strong ambient temperature fluctuations. You can rely on WAGO's vibration-proof, maintenance-free rail-mount terminal blocks.

- Reliable connections from 0.14 to 185 mm<sup>2</sup> (24 AWG–350 kcmil)
- Maintenance-free thanks to spring-loaded connection technology
- Ex eb I/II approval

## X-COM®S-SYSTEM

Modularize systems and improve system uptime via fast and flexible maintenance solutions. This is possible with the world's first pluggable rail-mount terminal block system with Ex area approval.

- Pluggable with all the advantages of our rail-mount terminal blocks
- Locking lever provides additional protection to prevent accidental disconnection
- Ex ec approval for use in Zone 2/22



More Information



WAGO power supply



Overvoltage protection



X-COM®S-SYSTEM

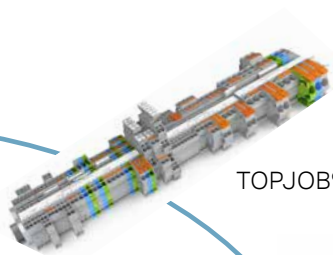

TOPJOB® S



POWER CAGE CLAMP



PCB terminal block

TOPJOB® S



## PCB Terminal Blocks

Reliably connect to your printed circuit board in explosion-prone areas: WAGO PCB terminal blocks are specially designed for use in hazard zones. With the 236, 255, 256, 257 and 745 Series, you're always on the safe side.

- Conductor cross-section range: 0.08 ... 16 mm<sup>2</sup>
- Ex e II approval
- CAGE CLAMP® connection

# WAGO I/O System 750

## Fieldbus-Independent I/O for Hazardous Areas

The modules within the WAGO I/O System 750 are designed for use in both non-hazardous and hazardous areas.

The direct use of fieldbus technology in hazardous areas makes unique demands on the systems. When used in Zone 2/22 hazardous areas, the WAGO I/O System 750 offers safe, easy, economical connection to the sensors/actuators of Zones 0/20 and 1/21.

The "blue" Ex i I/O modules were specially developed for this purpose. They form an intrinsically safe segment that can be integrated into a standard fieldbus node, offering all the advantages of state-of-the-art fieldbus technology.

### The WAGO I/O System 750 has approvals for use in:

- Mining
- Explosive gas environments
- Explosive dust environments
- Onshore/offshore environments (gas tankers, oil/gas fields, etc.)



### Worldwide Approvals

- International approvals for process engineering and the marine industry (e.g., ATEX, IECEX, UL OrdLoc, UL HazLoc, Inmetro, CCC Ex, EAC Ex, KCs, UKEx, DNV) guarantee worldwide use – even under harsh operating conditions

### Maximum Fieldbus Independence

- Modular design supported by numerous fieldbus systems and ETHERNET standards
- Fieldbus couplers, controllers and communication modules for a huge variety of protocols, depending on your application
- Fine modularity
- A large variety of components



### Maximum Flexibility

- Bus supply modules permit different voltages within the same node
- Standard I/O modules can be combined with intrinsically safe Ex modules in one node

### Compact Solution

- The extremely compact I/O nodes make the system a perfect fit in the most compact spaces
- Space-saving design with functional safety and explosion protection combined in one module

### Numerous Specialty Functions

- Analog functions (RTD, TC, AC/DC), NAMUR
- HART protocol support
- Extensive diagnostic features (e.g., short circuit, line break and out-of-range measurement)

### Maximum Ruggedness and Reliability

- The WAGO I/O System 750 is also engineered and tested for use in the most demanding environments in accordance with the highest standards, such as those required in marine applications
- Continuous operation guaranteed thanks to Push-in CAGE-CLAMP® spring contacts

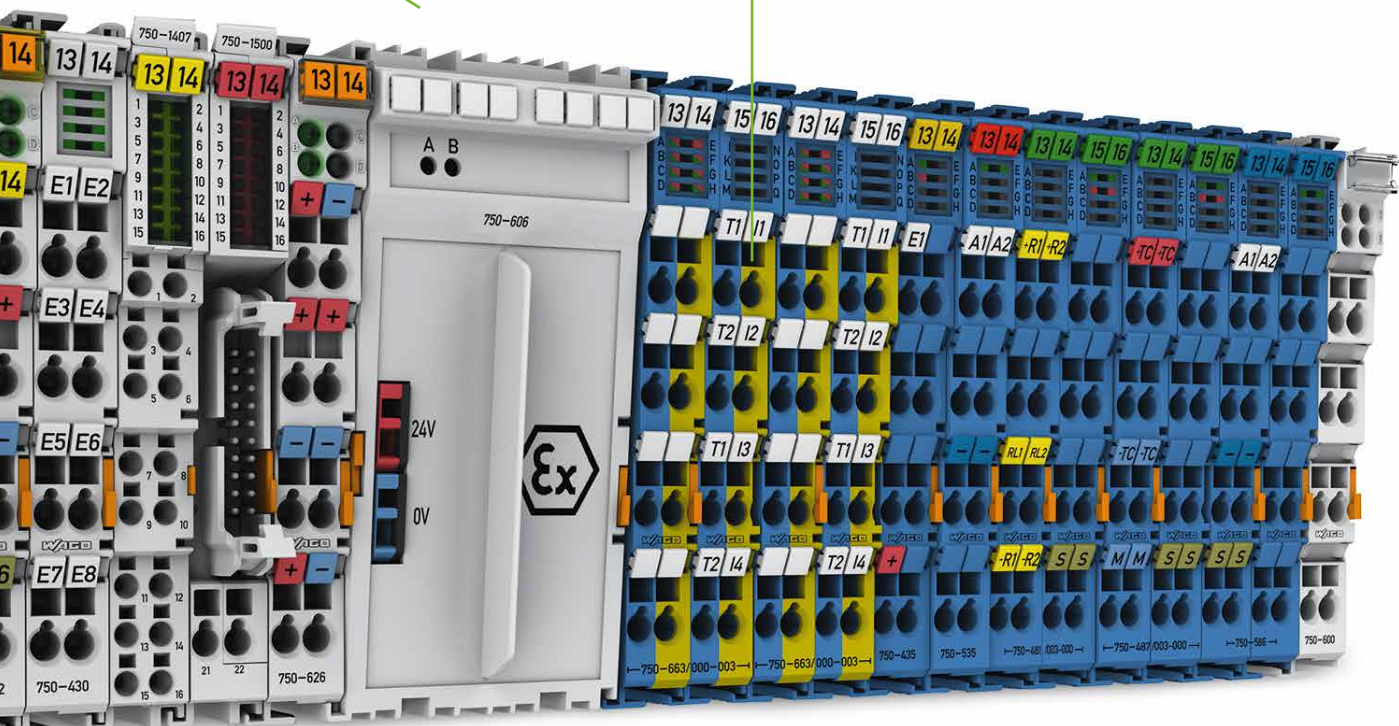

# Powertrain

## Complex Value Creation Needs High Reliability

The term “powertrain” refers all the areas where drivetrain components are produced, including engines, transmissions, clutches, axles, batteries and electric motors. Combining all these elements creates a vehicle’s entire powertrain. Finally, the manufactured components need to be available at the specified time at the correct location for engine/transmission assembly. Such precision requires an absolutely reliable automation solution.

For assembly lines or processing centers used in powertrain areas, safe system startup, shutdown and return to a specified condition need to be guaranteed at all times. The purpose of this requirement is to prevent avoidable faults in the power supply and associated downtime. Here too, it is important to keep an eye on manufacturing costs and to increase efficiency. WAGO’s power supplies and circuit breakers were engineered to meet these requirements.

WAGO’s 787 Series electronic fuses help prevent accidental tripping due to high inrush currents or unintended startup of equipment in the event of a fault. Function blocks for ECB monitoring via the WAGO I/O System or other control systems are available for free. The electronic circuit breakers (ECBs) have digital inputs and outputs that communicate via Manchester protocol. All channels allow independent remote diagnostics and switching. These options allow plant operators to implement preventive maintenance and reduce costly production downtime.







# More Energy in the Field

## The WAGO Power Supply for IP67 Applications

Out of the control cabinet and into the field: Thanks to a robust design and high protection type rating, WAGO's power supply for IP67 applications gets energy right to where it's needed. Even under extreme environmental conditions, the new IP67 power supply performs reliably and withstands humidity and dust thanks to an IP67-grade design. The device is designed for efficiently supplying distributed loads with 24 VDC – robustly and energy-efficiently, right on site. The primary advantage of the new IP67 power supply is that voltage is converted from 230 VAC to 24 VDC only where direct current is needed, reducing energy costs through high efficiency. The IP67 power supply also saves space, since it eliminates the need for large devices in the central control cabinet. Designed for robustness and availability, WAGO's new power supply for IP67 applications is perfect for reliable use in decentralized applications.

### The Benefits for You:

- Compact, space-saving design for on-site installation
- Up to 92.3 % efficiency for economical operation over a long service life
- Rapid, tool-free wiring with 7/8" screw-clamp connections
- Active power factor correction for drawing clean sinusoidal power from the grid
- Effective water splash protection for use in harsh industrial environments

Go to the product:



# The WAGO Power Supply for Your IP20 Applications

## Efficiency

Up to 96.6 % efficiency\* throughout a wide load range: That's the key to cutting energy costs, reducing power losses and requiring less control cabinet cooling. It also dramatically reduces the carbon footprint. WAGO's Pro 2 Power Supply can be permanently connected to a PLC via the communication module or a digital signal, allowing the power supply output to be switched off via a signal and standby mode to be used to save energy.

## Lower CO<sub>2</sub> emissions/energy costs

with up to 96.6 % efficiency\*

**Energy cost savings** via standby mode activation

\* Measured on 2787-2348



# 96.6 %

## Load Management

Rapid switching of capacitive loads and high start-up currents are no problem, thanks to 150 % output power (PowerBoost) for five seconds. Output current up to 600 % for 15 ms provides reserves for rapidly and reliably tripping miniature circuit breakers. The ability to allow a specified output current to be exceeded for a configurable amount of time allows the Pro 2 Power Supply to work like a single-channel ECB.

**Fast and reliable** tripping of miniature circuit breakers **thanks to temporary output currents** up to 600 %

**Rapid charging** of capacitors and **fast switching** of contactors thanks to output currents up to 150 % for five seconds

**Configuration of the output**, e.g., as an electronic circuit breaker

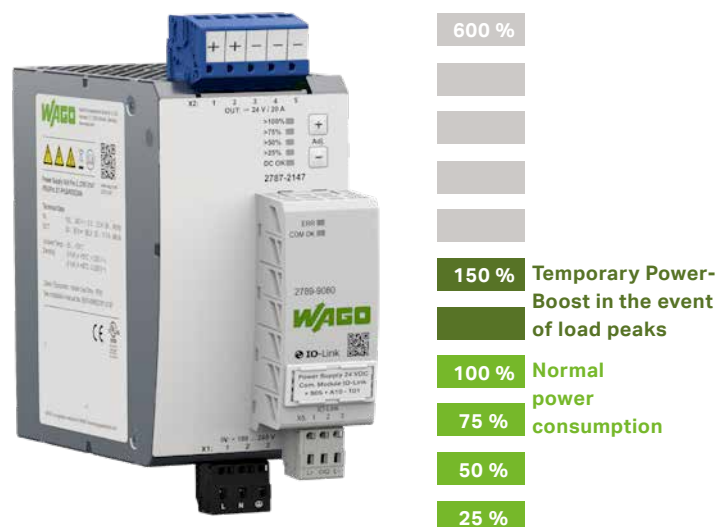

---

## Configuration

WAGO's new Interface Configuration Software offers both local/remote configuration and parameter setting, so you can tailor power supplies to your system requirements quickly and easily. The configuration function can be used to parameterize the power supply as an ECB. In case of an overcurrent, the output can be reactivated by the digital input – saving space and money for an external ECB, while protecting downstream devices.



Thanks to the **configuration options**, the power supply can be customized for **virtually any application**.

---

Configurable ECB functionality **reduces costs and space requirements** and **increases safety**.

## Communication

The pluggable communication module allows continuous fieldbus communication, provides data, such as actual output current and voltage, and can also be configured or put in standby mode remotely.

**Ready for digitization** thanks to modular fieldbus communication (IO-Link, Modbus RTU, Modbus TCP)

---

**A continuous overview** of all the data and values of your system's power supply

---

**Greater system uptime** thanks to early warning and predictive maintenance



# WAGO Pro 2 Power Supplies

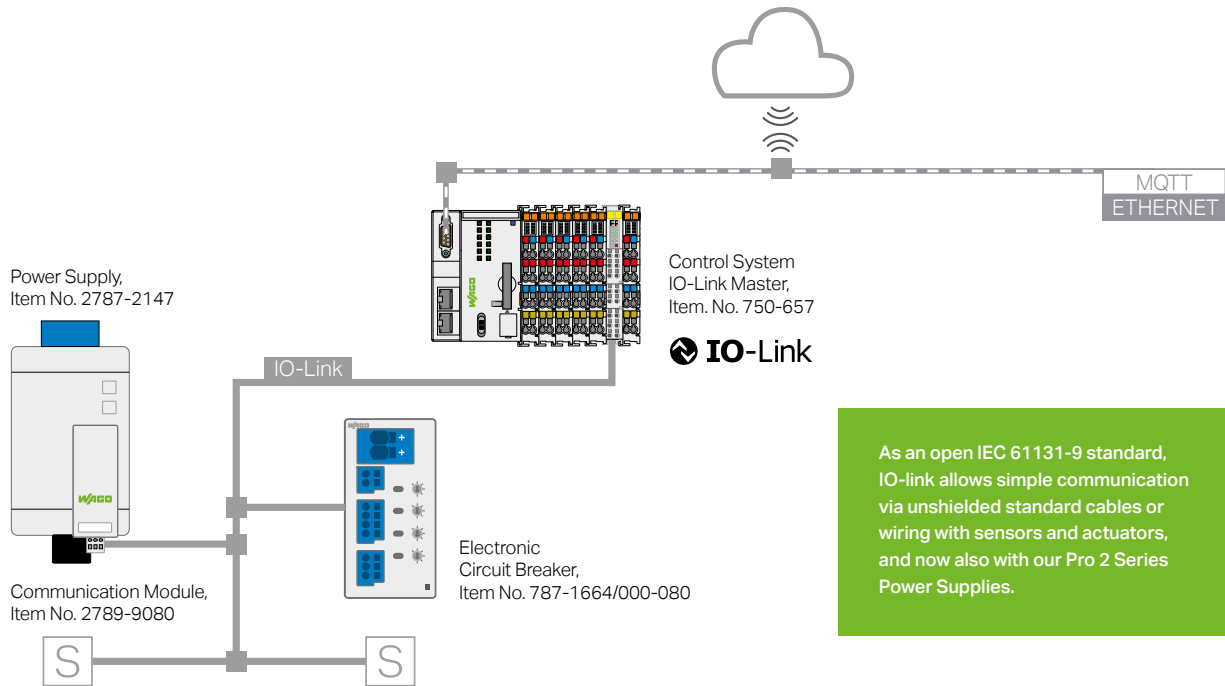

As an open IEC 61131-9 standard, IO-link allows simple communication via unshielded standard cables or wiring with sensors and actuators, and now also with our Pro 2 Series Power Supplies.



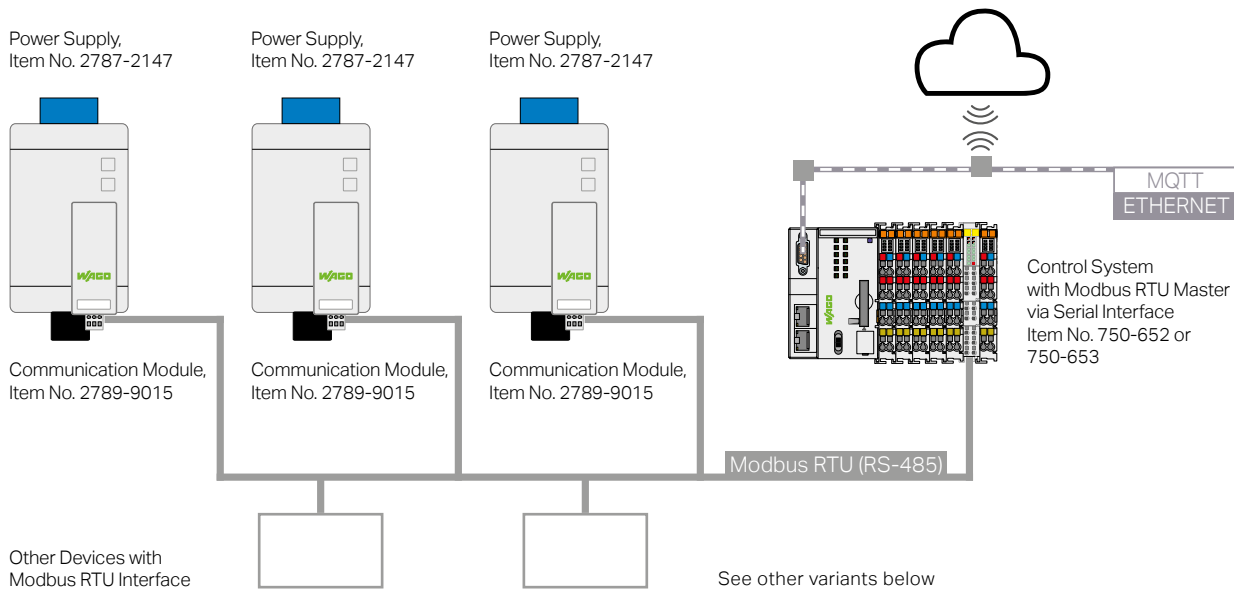

## IoT-Ready via Communication Module

In addition to their traditional function as a converter, modern power supplies can provide valuable data to help guide preventive maintenance and service, for example. The snap-on type IO-Link Communication Module connects Pro 2 Power Supplies to a PLC or an IoT controller. A significant advantage of this is that it makes the current, voltage and operating states of the power supplies available at all times, enabling quick responses to production process deviations. In addition, output voltage and signaling, for example, can be adjusted thanks to a function

block in the PLC program or a parameter server – even for changes during operation.

The main communication partner can be the WAGO I/O System, for instance. Powerful WAGO PFC Controllers serve as data loggers; a simple MQTT software extension then turns these into IoT controllers with cloud connectivity.



2789-9080  
IO-Link



2789-9015  
Modbus® RTU



2789-9052  
Modbus TCP



2789-9023  
Ethernet IP/MQTT

# Secondary-Side Fusing

## How Using Electronic Fuses Keeps Your Production Running

Standard switched-mode power supplies often fail to trigger conventional line protection devices properly in the event of a fault. The explanation is relatively simple: Due to a lack or insufficiency of overload capacity, switched-mode power supplies are unable to supply three to five times the overcurrent required to trigger a B-character machine, for example. The result is a drop in the 24 V voltage and an undefined system status. The 24 V power supply to controllers, valve terminals or sensors can no longer be guaranteed. The fault's cause is difficult for maintenance technicians to locate, which extends downtime.

WAGO's electronic circuit breakers (ECBs), keep your system under control even in the event of a fault. Reliable electronic fuse tripping maintains the 24 V power supply, and only the faulty current path is safely switched off. WAGO's ECB also uses a red LED to indicate which channel/fuse tripped. This all facilitates maintenance technicians' troubleshooting work and helps reduce possible production downtime.

Communication with the control system can use a simple digital signal, a Manchester Code or IO-Link. In addition, other diagnostic data can be transmitted, such as the current value setting, the current flowing presently or the quality of the 24 V supply. This, in turn, increases system uptime.

**Switch off secondary-side overcurrents and short circuits – even with long cable runs and small conductor cross-sections – with precision, speed and repeatability**

- Selectivity, especially with ECBs with active current limitation
- Remote operation via digital input and output
- Readout functions (communication) through serial data transfer via digital input and output or IO-Link
- Convenient installation size and width, for example, eight output channels in just 42 mm (1.653 inch), which reduces the installation space by more than 70 % compared to miniature circuit breakers
- Adjustability thanks pre-settable nominal current for each channel
- Satisfy EN 60204-1 requirements for reliably switching off ground faults after five seconds (see right)



# Our Product Portfolio



1-Channel ECBs

### The Benefits for You:

- 24 VDC available with nominal currents from 0.5 to 8 A
- Versions with permanently set or configurable trip current
- Very slim 6 mm design
- High switch-on capacities
- Resetting and on/off switching directly on the module or remotely via digital input signal
- “Tripped” signal output – can also be commoned as a group signal for up to 30 devices



2-, 4- and 8-Channel ECBs

### The Benefits for You:

- 2-, 4- and 8-channel circuit breaker with currents adjustable from 0.5 to 12 A
- High switch-on capacity: > 50,000  $\mu\text{F}$
- Communication interface allows remote monitoring
- Also available with active current limitation
- Numerous approvals (CE, UKCA, UL 60950, UL 2367, DNV) allow a wide range of applications

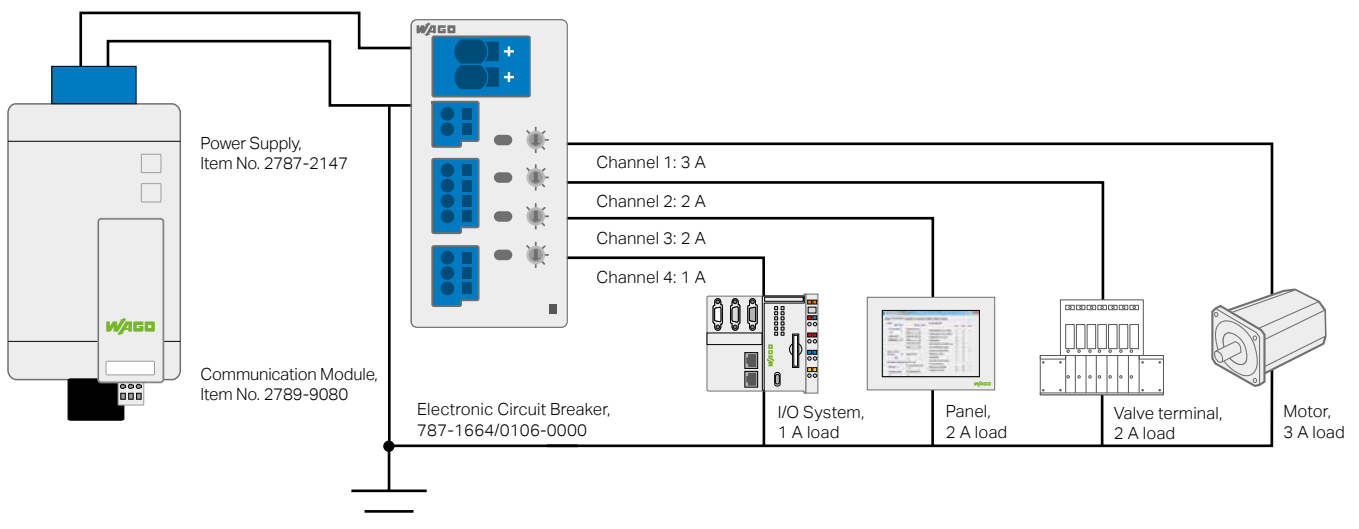

# Industrial Managed Switches

## PROFINET – Use in Industrial Automation

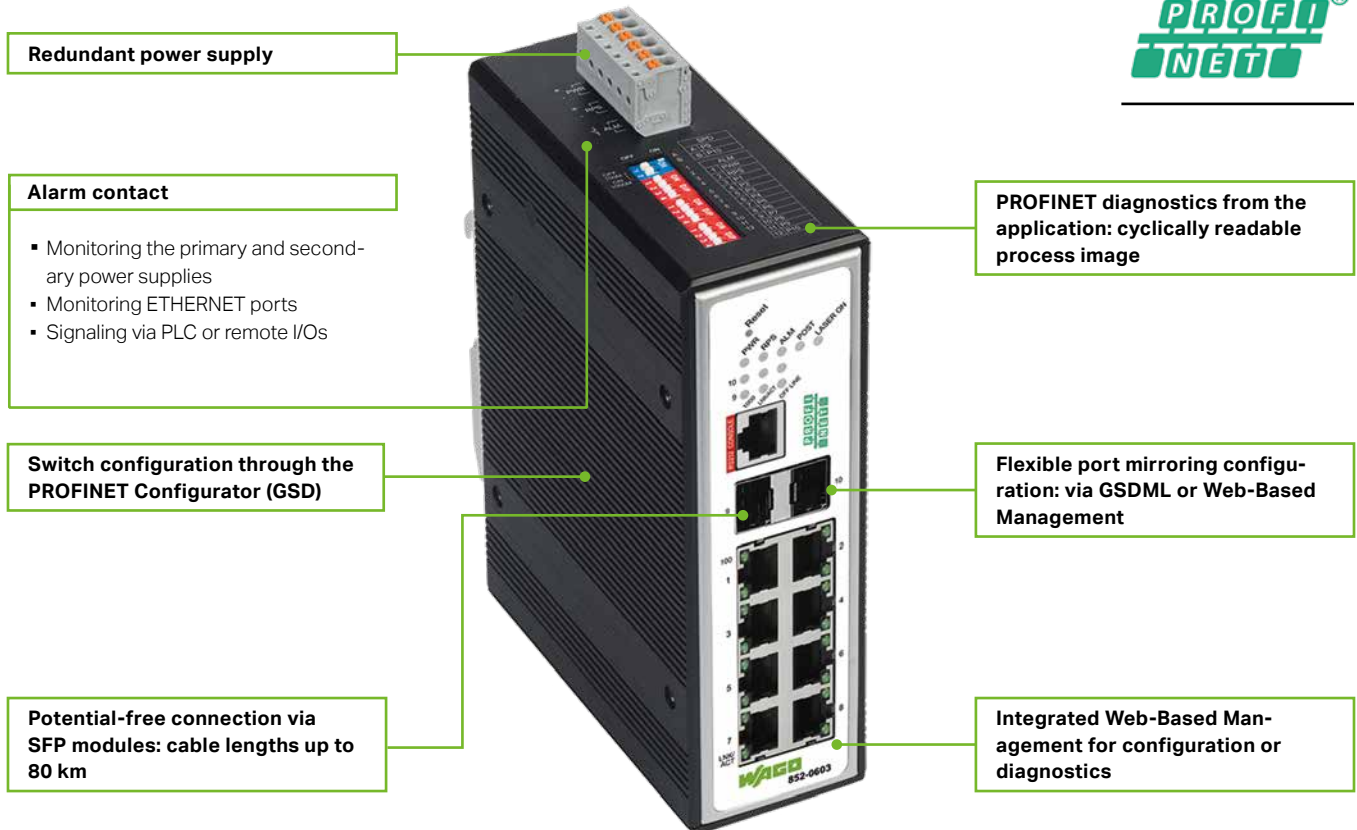

\*Small Form-factor Pluggable interface for fiber optic cables

			
<b>Copper ports</b>	8 × 10/100BASE-TX	8 × 10/100BASE-TX	8 × 10/100/1000BASE-T
<b>SFP ports</b>		2 × SFP 100/1000 <sup>2</sup>	4 × SFP 1000BASE-SX/LX
<b>Supply voltage</b>	12 ... 60 VDC	12 ... 60 VDC	12 ... 60 VDC
<b>Redundant power supply</b>	■	■	■
<b>Alarm contact</b>	■	■	■
<b>Dimensions (W × H × D)</b>	50 × 162 × 122 mm	50 × 162 × 122 mm	50 × 162 × 122 mm
<b>Ambient temperature (operation)</b>	-40 ... +70 °C	-40 ... +70 °C	-40 ... +70 °C
<b>Approvals</b>	UL	UL	UL
<b>Prioritization</b>	IEEE 802.1Q	IEEE 802.1Q	IEEE 802.1Q
<b>PROFINET</b>	CC-B	CC-B	CC-B
<b>Item No.</b>	<b>852-602</b>	<b>852-603</b>	<b>852-1605</b>

Suitable SFP modules on page 16

<sup>2</sup> Configurable via DIP switches (1000BASE-SX/LX or 100BASE-FX)



# PROFINET-Specific Features

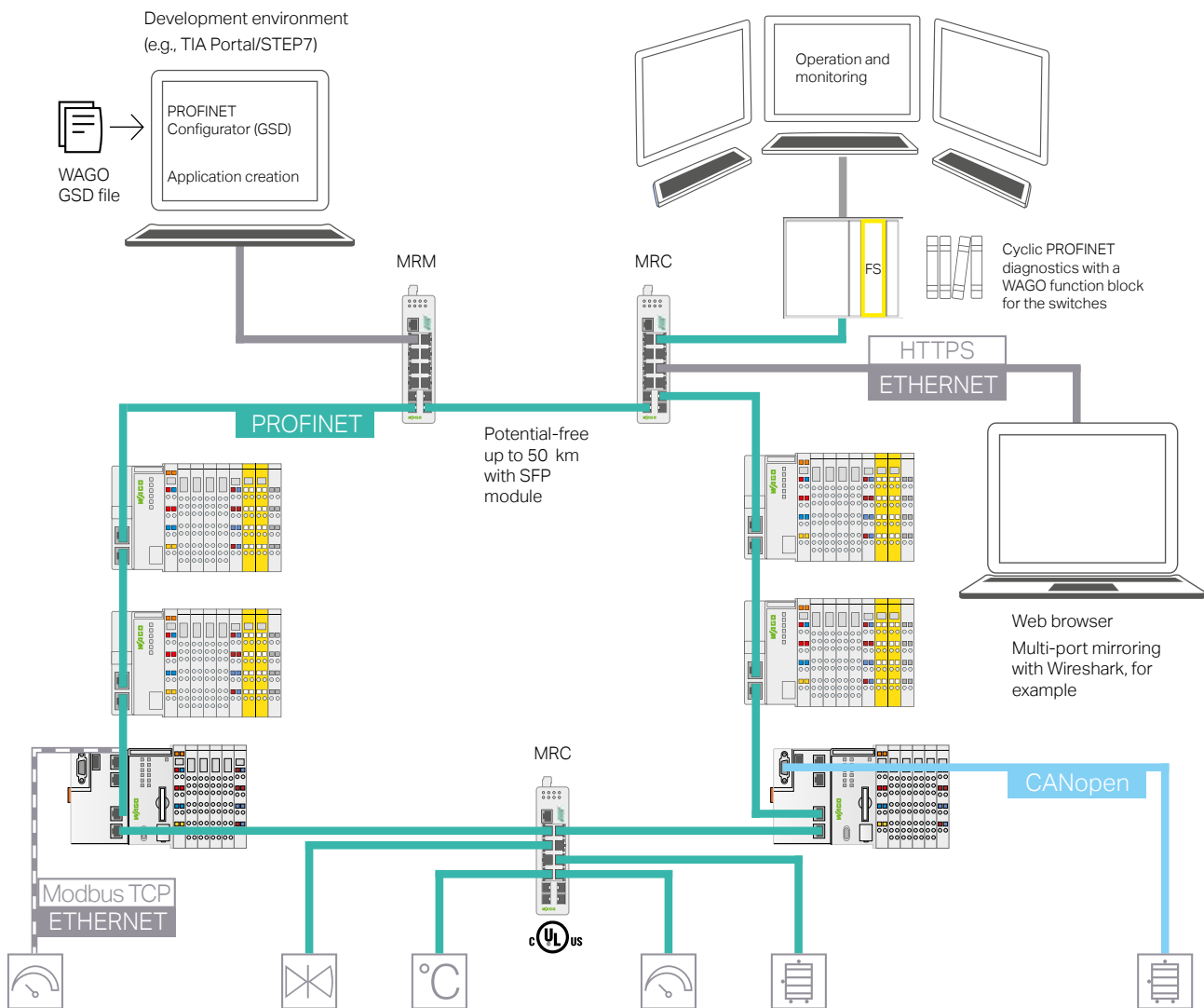

The following products meet the requirements of PROFINET conformity class A (CC-A):  
 852-1111, 852-1112, 852-1411,  
 852-1411/000-001 and 852-1417

### Special Product Features:

- Prioritized PROFINET data packet forwarding
- Configuration via GSDML file not possible
- Neighborhood detection and PROFINET diagnostics not possible

### The Benefits for You:

- Use in industrial automation thanks to PROFINET certificate (conformity class B)
- Port-independent configuration of the media redundancy protocol as a manager (MRM) or client (MRC)
- Flexible multi-port mirroring configuration via device description file
- Switch configuration with device description file

# RJ-45 Connector

## Fast, Tool-Free Installation

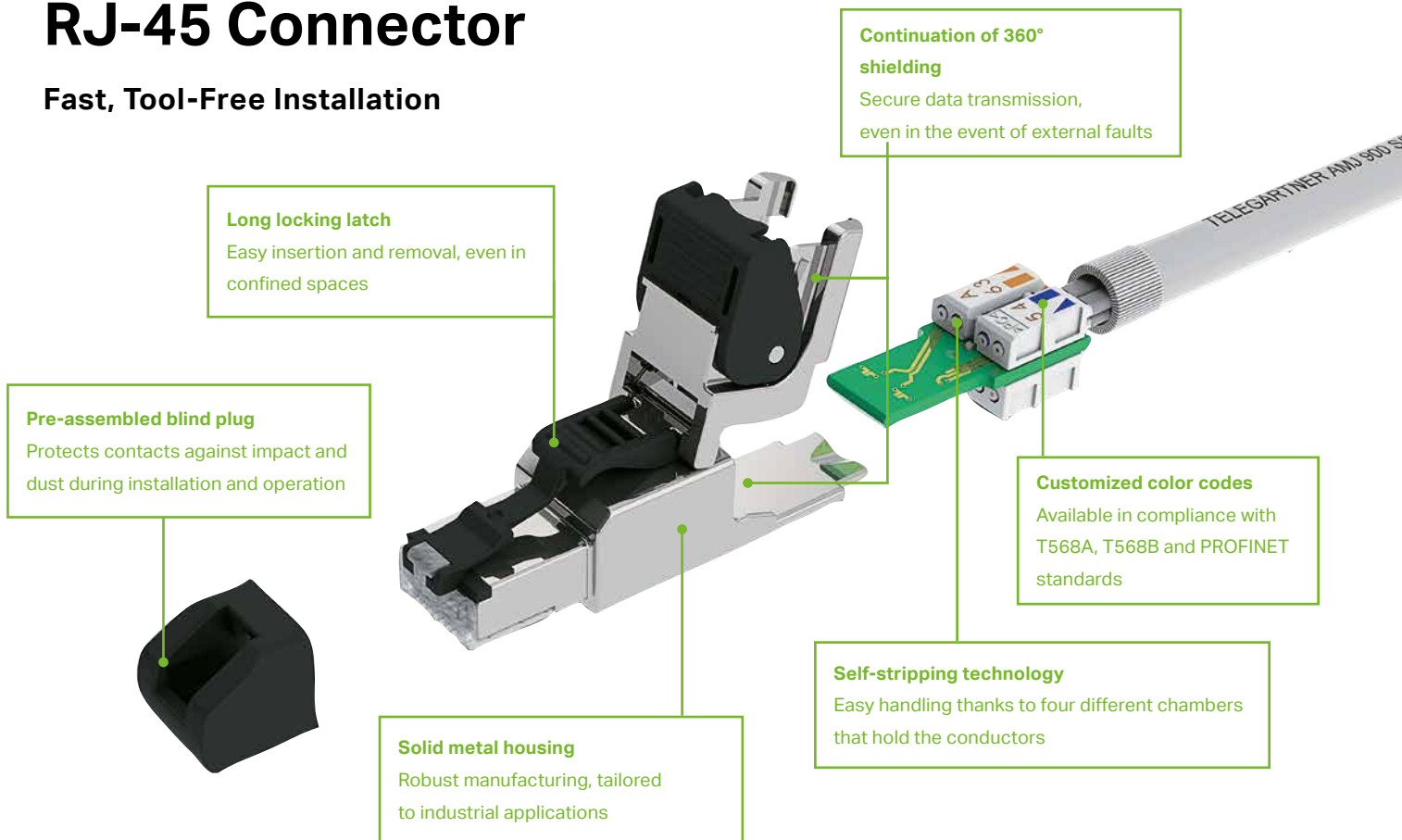

RJ-45 Connector







Category	Cat. 6a	Cat. 6a	Cat. 6a
Max. rate	10 Gbit/s	10 Gbit/s	10 Gbit/s
Housing material	Metal	Metal	Metal
Ambient temperature (operation)	-40 ... +85 °C	-40 ... +85 °C	-40 ... +85 °C
Cable Clamp	-	Straight output	Angled output
Conductor cross-section <sup>1</sup>	0.21 ... 0.32 mm <sup>2</sup>	0.21 ... 0.32 mm <sup>2</sup>	0.21 ... 0.32 mm <sup>2</sup>
ETHERNET T568B <sup>2</sup>	<b>750-977/000-012</b>	<b>750-978/000-012</b>	<b>750-979/000-012</b>
PROFINET <sup>3</sup>	<b>750-977/000-013</b>	<b>750-978/000-013</b>	<b>750-979/000-013</b>

<sup>1</sup> Also available for conductor cross-sections from 0.13 to 0.21 mm<sup>2</sup>, item no. 750-97x/000-02x

<sup>2</sup> Also available for ETHERNET T568A, item no. 750-97x/000-011

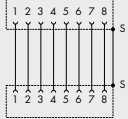
<sup>3</sup> Max. rate for PROFINET: 100 Mbit/s

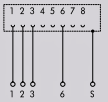
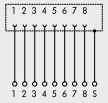
## RJ45 Interface Modules

Illustration	Description		Item No.	EAN No.
	RJ45 interface module, mounting carrier for DIN-35 rail		<b>289-172</b>	4045454317478
	RJ45 interface module, with shield clamping unit for WAGO shield clamping saddle, mounting carrier for DIN-35 rail		<b>289-174</b>	4045454317492
	RJ45 interface module, with shield clamping unit for WAGO shield clamping saddle, mounting carrier for DIN-35 rail		<b>289-175</b>	4045454317522
	RJ45 Cat.6 interface module with shield, mounting adapter for DIN-35 rail		<b>289-195</b>	4055143292986
	WAGO shield clamping saddle (11 mm wide; cable diameter up to 8 mm)		<b>790-108</b>	4017332356954

For automotive production to work, it needs professional installation of network cabling. In existing production systems in particular, network cables often have to be extended or new network cables have to be assembled.

Setup and retrofitting of cabling is a potential source of error. If network cabling is installed incorrectly or is prone to faults, this can lead to significant production stoppages.

To minimize production downtime, WAGO offers RJ45 Ethernet plugs and cabling specifically designed for industrial applications.

WAGO's RJ45 Ethernet plugs and interface modules ensure fast, error-free installation.

### The Benefits for You:

- Quick and error-free network connection via tool-free connection technology
- Vibration-proof locking mechanism prevents communication loss during production
- Secure assembly of the TIA-568A/B and PROFINET standards via embossed color coding
- Secure data transmission, even in the event of external interference, via 360-degree shielding
- Angled housings and cable outlet locking with four 90° steps allow efficient, reliable on-site assembly, even very tight spaces

#### Configuration/Diagnostics/Maintenance

- Port mirroring, Modbus® registers
- SNMPv3, SNMP trap events
- Alarm threshold
- Port statistics
- Backup and restore
- System log
- Syslog server
- Command line interface with SSH/Telnet

#### Redundancy/Availability

- Loop detection
- STP/RSTP
- ETHERNET Ring Protection Switching (ERPS)
- Redundant power supply
- Storm control

#### Security

- Network segmentation per IEEE 802.1Q
- Network subscriber authentication per IEEE802.1X
- Firewall functions using access control list/ service control
- Port security



## Lean Managed Switches

### Intuitive Network Monitoring and Configuration

				
<b>Item No.</b>	<b>852-1812</b>	<b>852-1813</b>	<b>852-1813/000-001</b>	<b>852-1816</b>
<b>Copper ports</b>	8 × 10/100/1000BASE-T	8 × 10/100/1000BASE-T	8 × 10/100/1000BASE-T	16 × 10/100/1000BASE-T
<b>PoE+ ports</b>	-	-	8 × PoE+ (30W per port) <sup>1</sup>	-
<b>SFP ports</b>	-	2 × SFP 100BASE or 1000BASE <sup>1,2</sup>	2 × SFP 100BASE or 1000BASE <sup>1,2</sup>	-
<b>Supply voltage</b>	24 ... 48 V	24 ... 48 V	24 ... 57 V	12 ... 60 V
<b>Redundant power supply</b>	■	■	■	■
<b>Alarm contact</b>	■	■	■	■
<b>Dimensions (W × H × D)</b>	50 × 116 × 100 mm	50 × 116 × 100 mm	50 × 120 × 160 mm	50 × 120 × 160 mm
<b>Ambient temperature (operation)</b>	-40 ... +60 °C	-40 ... +60 °C	-40 ... +60 °C	-40 ... +60 °C
<b>Approvals</b>	UL	UL	UL	UL
<b>Prioritization</b>	IEEE 802.1Q	IEEE 802.1Q	IEEE 802.1Q	IEEE 802.1Q
<b>Topology map/dashboard</b>	■	■	■	■

<sup>1</sup> Suitable SFP modules on page 21

<sup>2</sup> Configurable via Webserver or DIP switch

# Intuitive Diagnostics and Operation

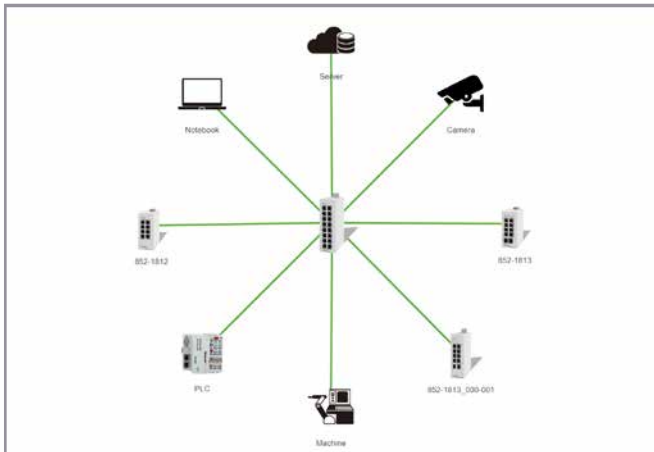

## Clear Operating Principle

For WAGO, an intuitive, easy-to-use interface is a high priority. Web-Based Management allows installation, commissioning and diagnostics to be performed without extensive IT knowledge. Users enter the switch's IP address in a standard browser and then access the diagnostic dashboard or network view (topology map) directly.

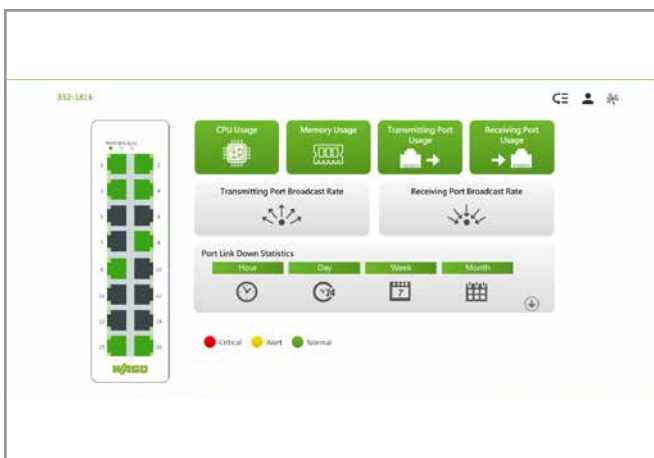

## Easier Diagnostics

The diagnostic pages of WAGO's Lean Managed Switches expedite system troubleshooting. The individual connection statuses are clearly indicated by green, yellow and red traffic lights. Hovering the mouse over a connection displays a detailed status overview for the individual connections. In a new window, the user can then see the bandwidth, the load and any transmission errors.



## Robust and Reliable

The operating principle and the hardware are perfectly attuned to each other. In addition to their ease of use and compact design, these DIN-rail mount switches also feature an extended temperature range. A redundant power supply ensures even more uptime. Security features like network segmentation per IEEE802.1Q, authentication of network devices per IEEE802.1X and port security complete the total package.

# Final Assembly

## Intelligent Control and Precision in Harmony

The final assembly process is the last step in automobile manufacturing. All the required components are installed in the vehicle's interior and exterior. The most important step in final assembly is the "marriage," i.e., the moment the drivetrain and engine are connected to the body. Customizations for the specific order are implemented in both previous and subsequent steps. A high degree

of precision and intelligent control ensure that custom parts are installed in the correct order at the specified points. Various safety fittings also need to be checked and documented automatically. Therefore, the process makes particularly high demands on the control system used. Stopping production during final assembly is not acceptable.

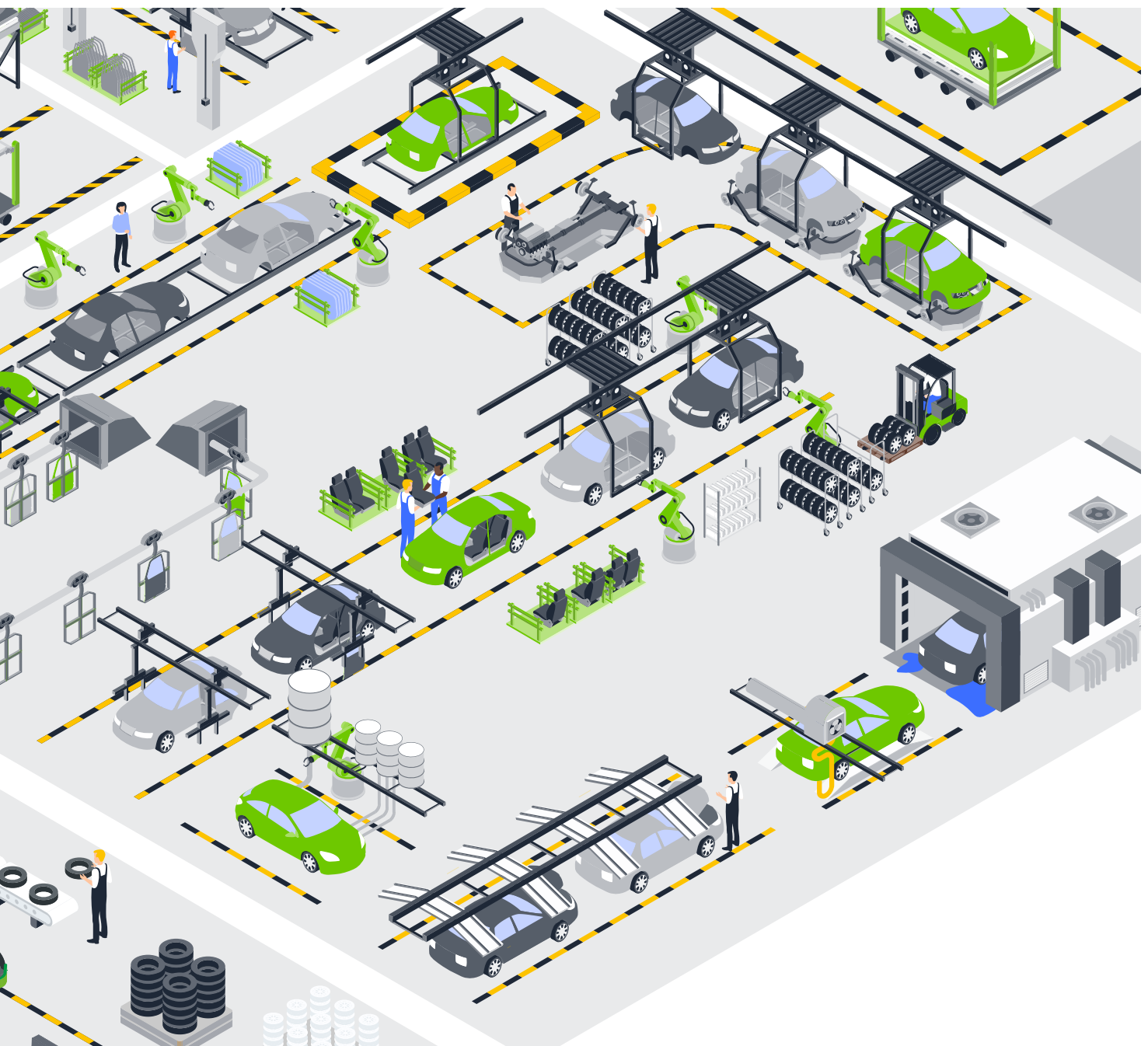

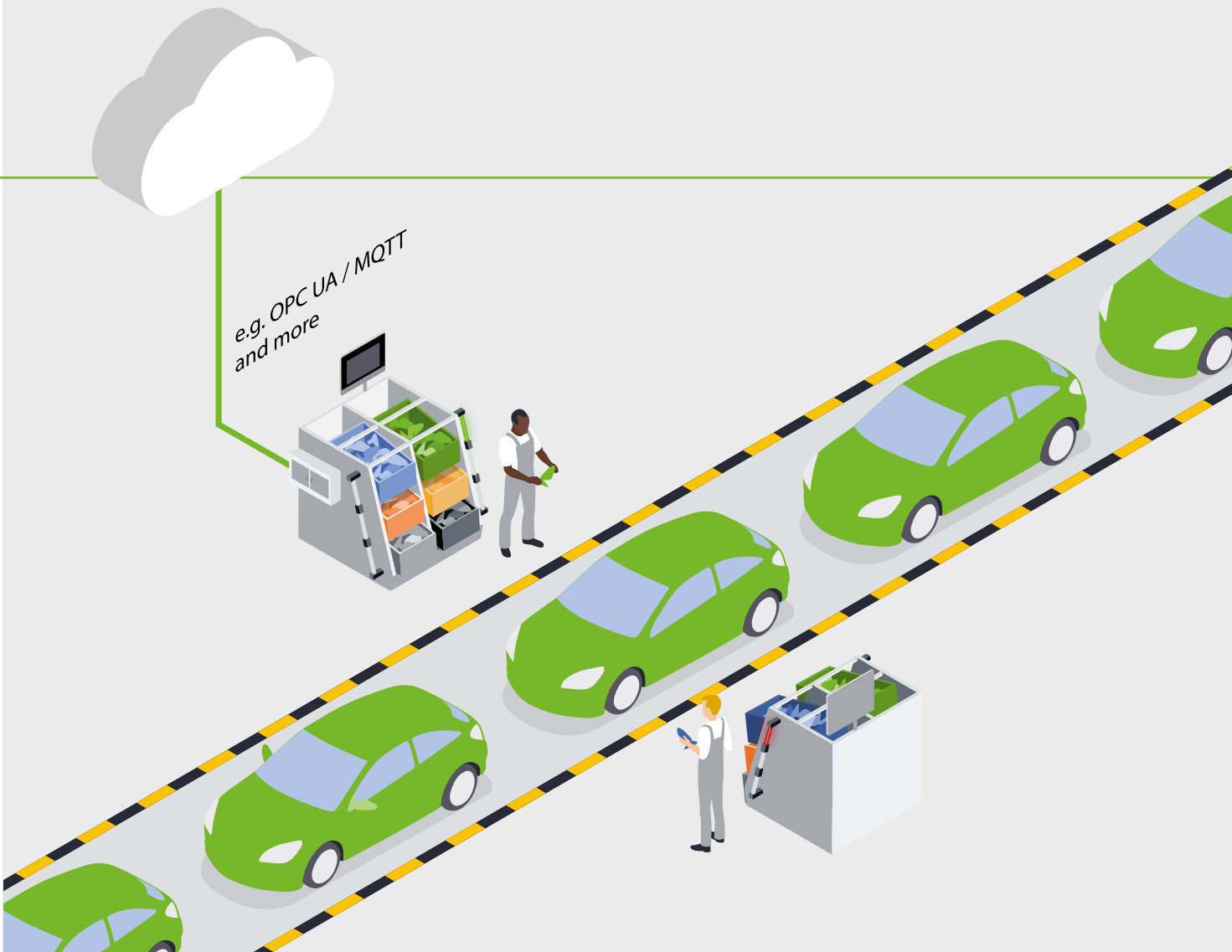

# Pick-by-Light

## The WAGO I/O System Always Ensures the Right Grip

Pick-by-light is a “paperless picking method.” In automotive assembly, light guides the operator to the storage location of the component to install next. This process also monitors the order and the quantity of components removed. If components are removed in the wrong order or quantity, the conveyor belt stops and does not transport the vehicle on further. Almost every final assembly process within an automobile factory uses such a pick-by-light system. This “system-guided assembly” ensures 100 % assembly reliability even for many different variants. And a reliable system crucially requires a reliable, flexible control solution. With its comprehensive distributed peripherals, the WAGO I/O System offers the perfect synergy of flexibility and standardization. The large number of available fieldbus couplers and controllers allows you to connect the pick-by-light system to the higher-level control system. Meanwhile, the I/O level remains

unchanged. For example, you can switch from PROFIBUS to PROFINET without any rewiring. This saves time and money, for example, during commissioning.

The WAGO controllers are an excellent choice for controlling a pick-by-light storage system with maximum flexibility. Thanks to direct connection to higher-level control systems like MySQL and MS SQL, the WAGO controller can communicate directly with the databases. WAGO’s PFC Controllers with the Linux® operating system offer you additional flexibility. For complex tasks, you can choose between programming in IEC 61131 with **e!COCKPIT** or directly in Linux®.

# Facility Management with WAGO

## The WAGO I/O System – Universal, Compact, Economical

### Management

The management level connects the automation stations to the building management system. Standardized protocols make data exchange easy.

Thanks to modern information technology, the most important information from building automation is no longer restricted to in-house building management – it's now available at any time and place. However, this has certain technical requirements. WAGO's PFC Controllers are equipped with cloud connectivity and transfer data to WAGO Cloud – or any other MQTT broker.

### Automation

Automation stations control and regulate operational systems. ETHERNET has long since established itself as the dominant transmission medium within automation. WAGO's automation stations can be easily and efficiently interlinked using open, standardized bus protocols for building automation like BACnet IP, KNX IP or Modbus/TCP. I/O modules and fieldbus interfaces permit nearly any sensor or actuator to be connected from the field.

### Field

In the field, flexible, easy-to-install media are essential. WAGO offers a wide variety of such solutions: from products for directly connecting standard sensors and actuators via I/O modules, to a variety of fieldbus interfaces for two-wire subsystems (e.g., Modbus RTU, MP-Bus, M-Bus, BACnet MS/TP, KNX TP1 and LonWorks®), to connection to wireless systems like EnOcean®.

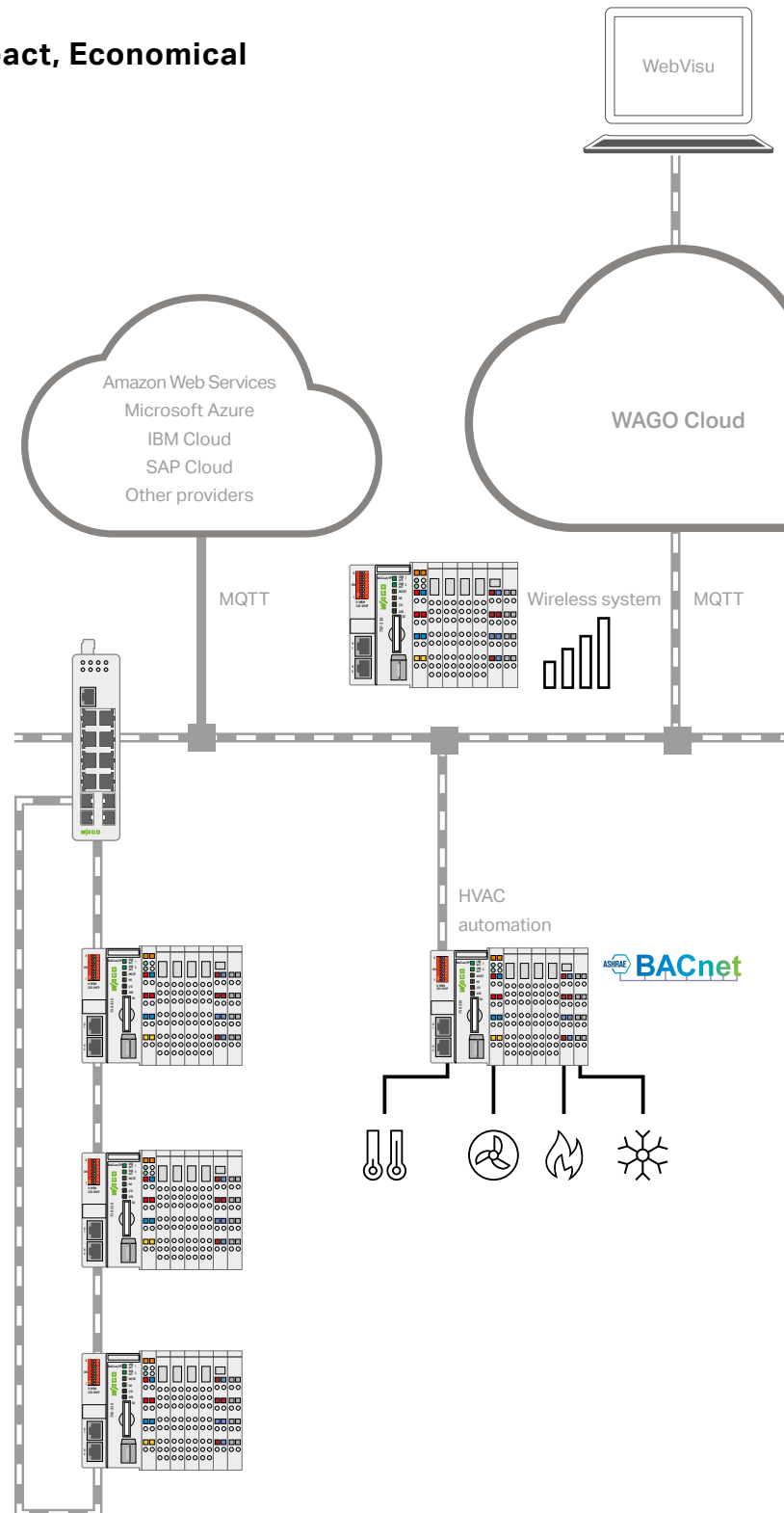







# HVAC Primary System Solutions

## Universal, Compact, Economical – the WAGO I/O System

Make the engineering, control and visualization of your projects even easier and more convenient with the PFC200 Controller thanks to **e!COCKPIT** and Linux®.

Shorter time to market for new products and a quicker return on investment – thanks to end-to-end software engineering, WAGO offers both. Thanks to an **e!RUN-TIME**-based runtime environment and real-time-capable Linux® operating system, the PFC200 Controller is the efficient control solution for your automation applications.

### Modbus®-Capable Manual Operation for the Control Cabinet Door

Multiple types of operation and display modules are available for different data point combinations. The controller connection is established via an RS-485 interface. Communication uses the Modbus RTU protocol.



More Information

#### The Benefits for You:

- Programming per IEC 61131-3
- Can be combined with high-level languages
- PLC and IT functions in one device
- Multiple interfaces, functions and application areas
- High cybersecurity standards (SSL, SSH, OpenVPN and firewall)
- Remote access via mobile communications

#### The Benefits for You:

- Clear arrangement and display of system status information
- Manual override of outputs via Modbus®
- Reduced time and effort for wiring
- Minimum mounting depth
- A library for integration into the I/O System

# TRIC Plans – Ready to Use

## From the System Diagram to the Finished Application

### System Macros

WAGO provides comprehensive templates, which include ready-made system macros for typical applications, to minimize the time and effort users need to devote to HVAC configuration. All that's left for them to do is configure the application – i.e., assign the data points and system parameters – and they can commission the completed application immediately. To simplify programming,

there are a multitude of pre-configured function blocks and applications available for free in the download area. Here you can also find templates for creating programs: comprehensive examples of complex tasks – including functional system macros with the corresponding documentation in PDF format. The manual override function within the system macros allows individual system parts to be overridden via the visualization screens.

### System Diagrams

In line with the applications, standardized system diagrams for CAD and TRIC are available for further use to allow easy integration into standard planning tools.



# Lighting Management

**Automotive manufacturing facilities need to allow flexible use over many years, because it is impossible to predict what the future of production will look like. Flexible conversion is a major challenge for the planning and design of the lighting technology. Modern lighting management offers more than just reduced energy consumption and costs – it combines cost-effectiveness and resource conservation with user comfort and flexibility.**

## Our Solution

WAGO Lighting Management is a proven solution based on predefined hardware and preconfigured software, which greatly simplifies planning, commissioning and operation. The basic idea: WAGO Lighting Management is ready for the vastly different light requirements of warehouses and production facilities. For example, a production facility can be divided into virtual rooms in which light can be adapted flexibly. Each virtual room receives signals from sensors and actuators in order to automatically set the appropriate light intensity. Virtual rooms allow conversions and remodeling to be implemented quickly and simply via Web configuration.

## Operation

WAGO Lighting Management features a Web interface that allows you to easily create and edit virtual rooms. Do you need to illuminate a production line, hallway or storage area? No problem – simply create three different virtual rooms with the desired functions. Parameter values can be stored on a backup server via FTP. The values can be passed on to a higher-level building control system or a production control center via Modbus TCP/IP.

**This approach is based on an intelligent lighting control system, which ensures that the correct light is available in the right amount at the right time by using daylight sensors, presence sensors and sophisticated lighting scenarios.**

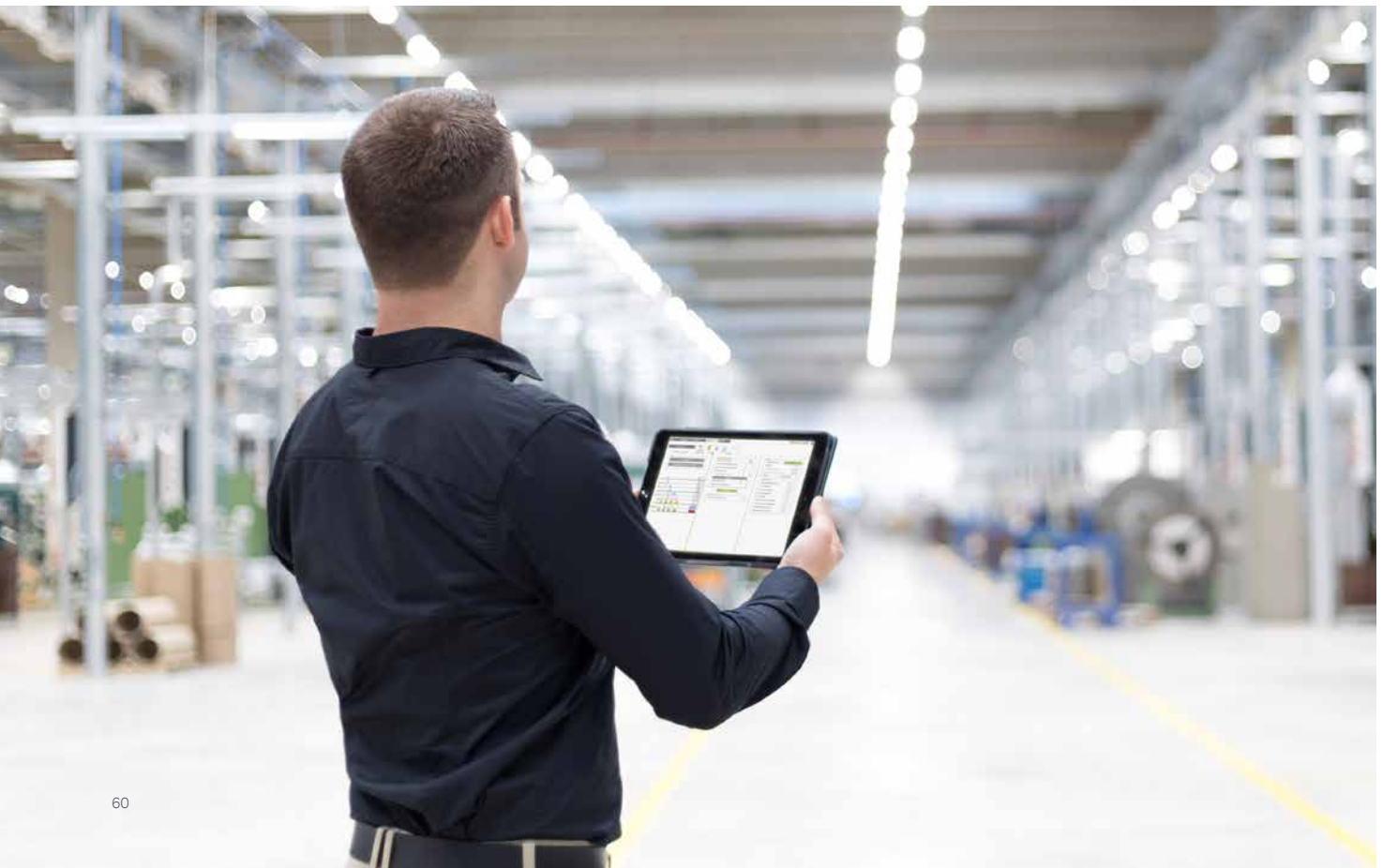

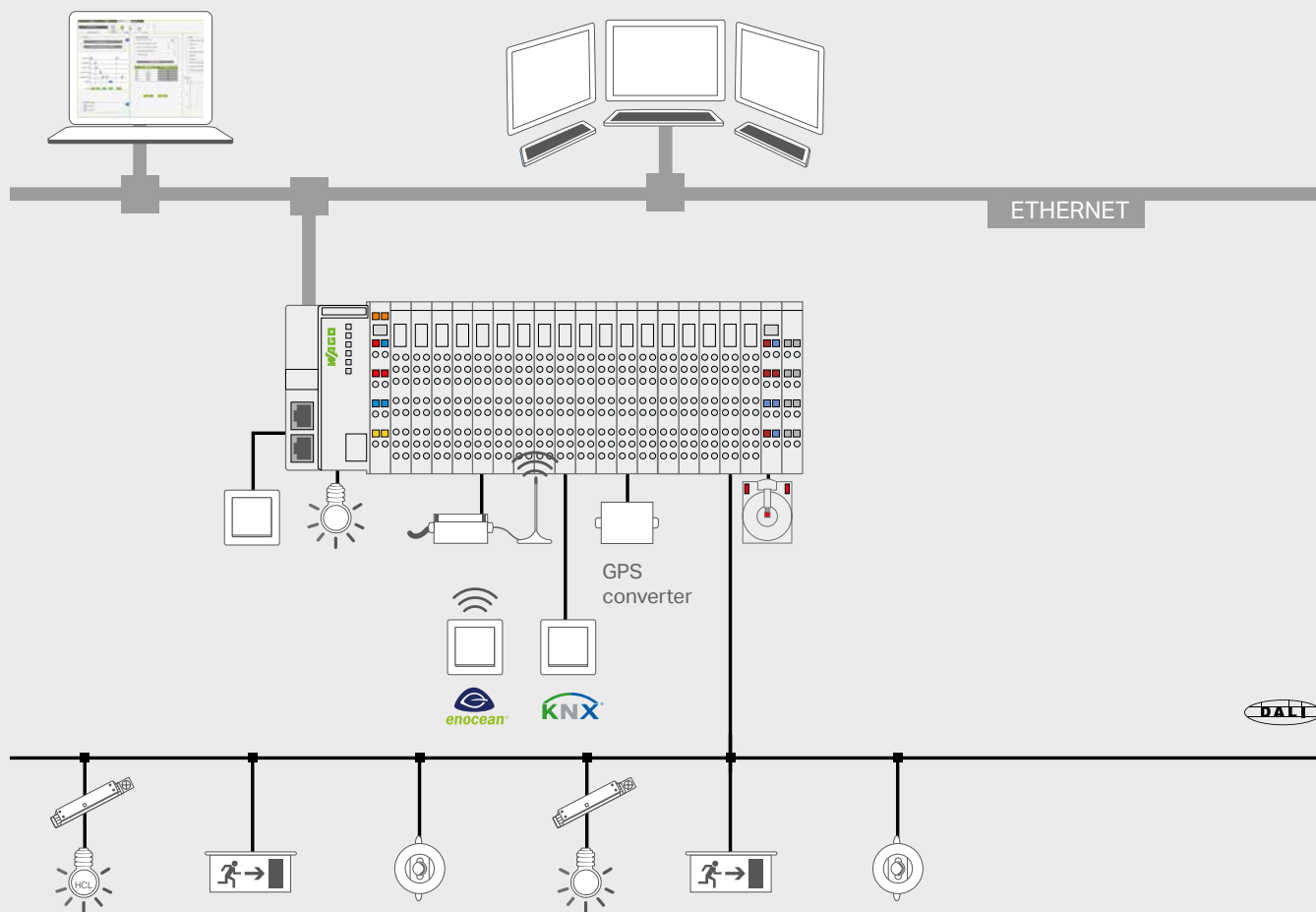

WAGO Lighting Management significantly reduces the total costs of initial commissioning and conversions. WAGO Lighting Management provides the perfect combination of high-quality hardware and intuitive software tailored to this application. Reduce lifecycle costs with quick and easy commissioning, comprehensive diagnostic and service capabilities and an easy way to adapt light to varying requirements.

Do you need to illuminate a large area?  
 No problem! WAGO's lighting management application allows you to illuminate about 3000 m<sup>2</sup>, depending on the type of lamp. For larger areas, it is easy to link several controllers together.

**The Benefits for You:**

- Efficient lighting management reduces lifecycle costs
- Scalable to your system requirements
- Commissioning via simple, self-guided wizard-based configuration
- Simple conversion without programming
- Connect to higher-level management and control systems within industrial or technical building environments



More information and videos

# A Measurement System with Added Value

## Record, Visualize and Analyze Energy Data Easily

With our Energy Data Management solution, you can record and visualize your measurement data for different media and variables in no time. Continuous acquisition and monitoring provide the basis for resource-efficient energy usage – protecting the environment and minimizing your operating costs. As an added bonus, conformity with DIN EN 50001 for energy evaluation is part of the package. WAGO Energy Data Management consists of Web-based application software combined with a modular control system. It records measurement data for different media, along with influencing variables for energy monitoring, and processes them for additional analysis, archiving and reporting. The software automatically detects different signals from the connected meters and sensors, making them

available to additional energy analysis tools via simple parameter settings. This information guides you in optimizing energy consumption in your building or production facility – whether your sites are clustered locally or distributed all around the world.

### The Benefits for You:

- Ready to go in a few easy steps
- No programming experience required
- Integrated cloud connectivity





# From the Building to the Production Line

## All the Basic Functions at a Glance

### Record Energy Data

Capture energy and environmental data from multiple sources, such as:

- Power consumption
- Gas volumes
- Heat/flow rates
- Volume flow
- Temperature

### Save and Archive Energy Data

You determine the file format and location for every one of your energy data files. Save it as needed

- In a database
- In the cloud (new!)
- As CSV files for data exchange with the control system

### Visualize Energy Data

Monitor your energy data anywhere:

- On a PC
- On mobile devices

### Alarms for Limiting Value Violations

Transfer your predefined thresholds to the system.

- Get notified immediately by email if your defined limits are violated
- In the event of limit violations, immediately take technical countermeasures remotely (e.g., switch off outputs)



Learn more at:  
[www.wago.com/energy-management](http://www.wago.com/energy-management)

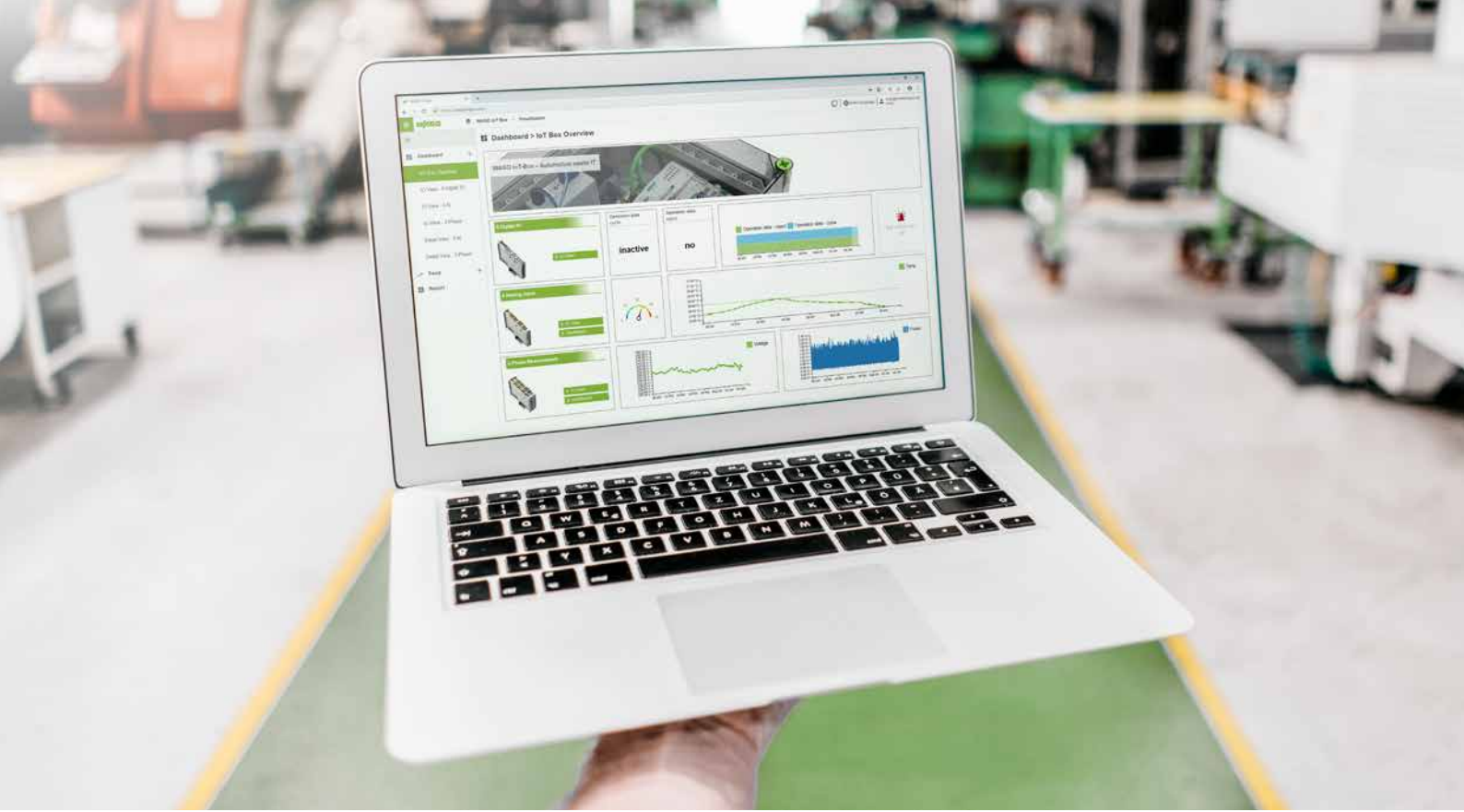

# Cloud Connectivity

Once the data has been collected, the next question is where and how it should be analyzed. Whether you use WAGO controllers as edge devices and pre-process the data, or the controllers send the data directly – cloud connectivity brings your Industrial Internet of Things (IIoT) project to life. With the WAGO controllers' large variety

of interfaces, it's also easy to link other manufacturers' devices to the cloud by using the WAGO controllers as an IoT gateway.

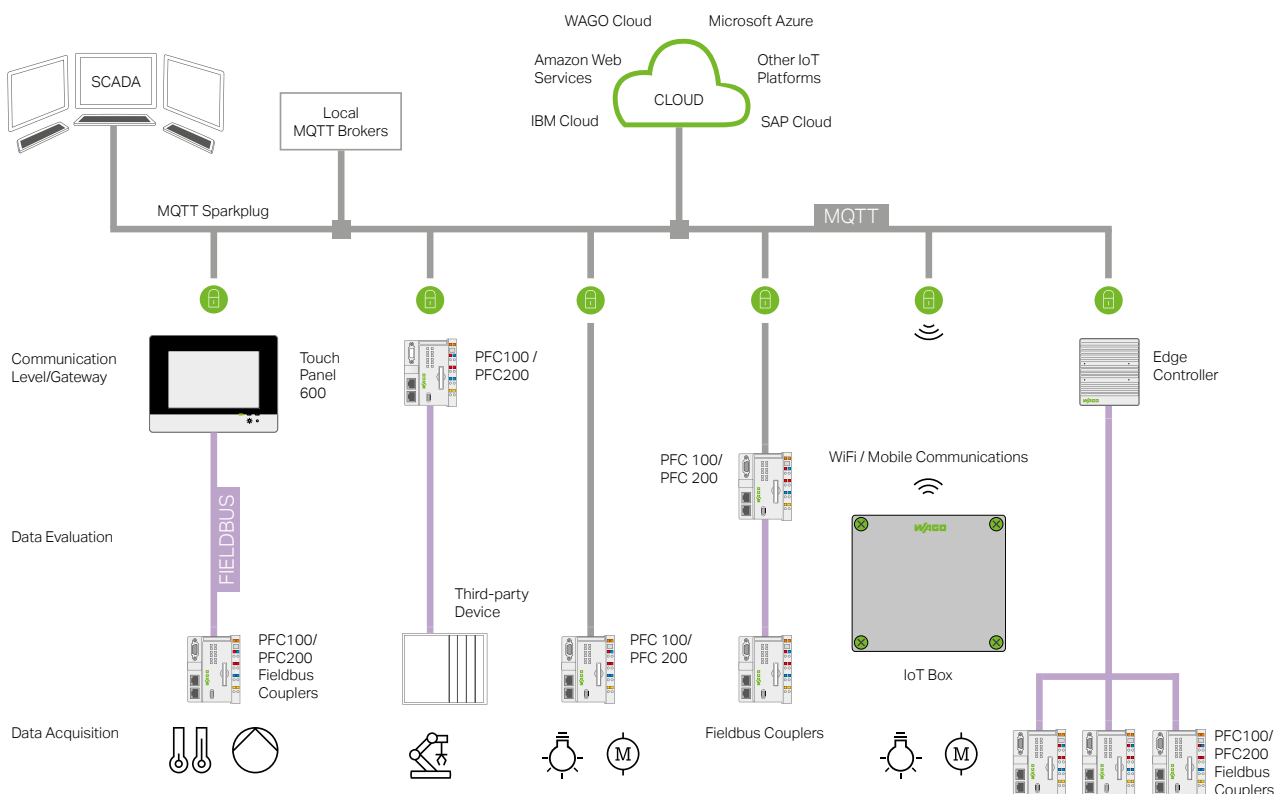



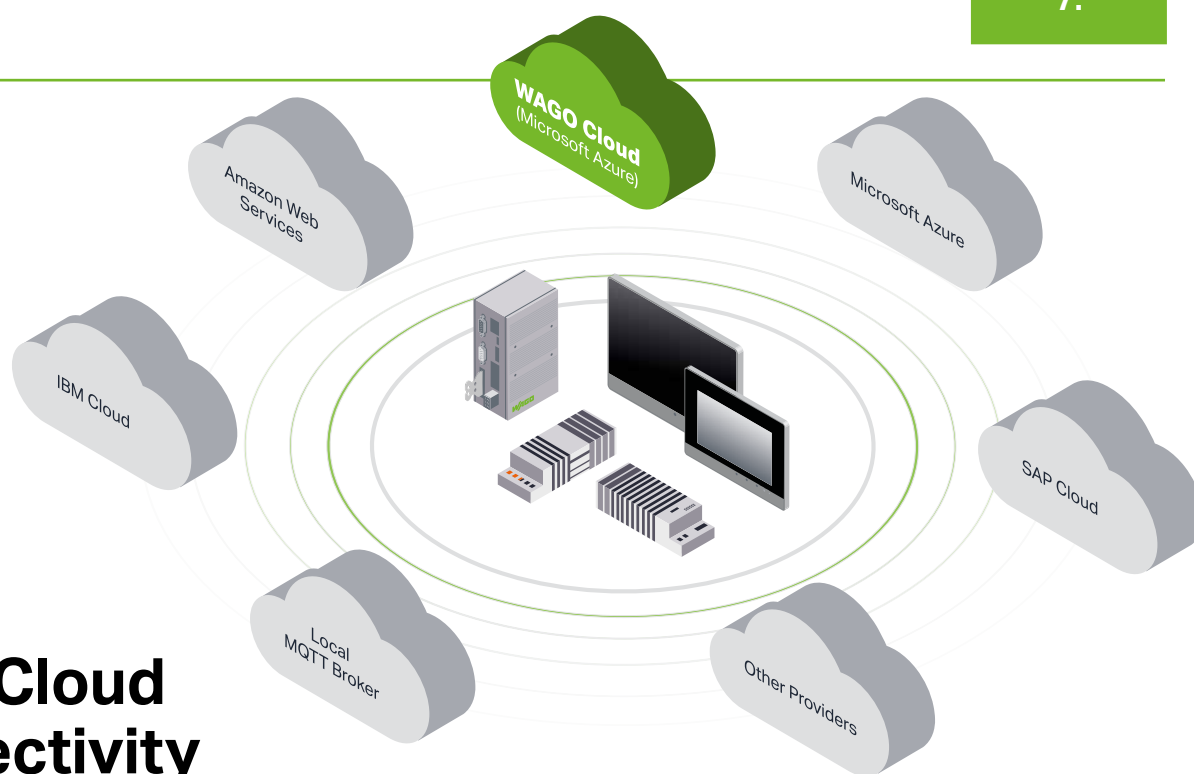

## Multi-Cloud Connectivity

Operating and display devices in the “Control Panel” software configuration allow simultaneous control and visualization, providing a very compact automation solution. Through use of a dedicated library, these panels become IoT controllers that send data from the field level to the cloud. Once in the cloud, this data can be aggregated and used for analysis. This capability creates tremendous added value for your company – whether for increasing the efficiency of in-house production, implementing energy management in buildings or developing additional end-customer services. Existing systems also become IoT-ready, making them future-proof.

### Future-Proof

Existing systems also become IoT-ready, making them future-proof. Communication between PFCs and cloud suppliers uses the MQTT protocol and encrypted via TLS 1.2. Cloud connection data is configured via Web-Based Management (WBM). With the corresponding library, the variables to transfer to the cloud can be defined in the PLC program, allowing the PLC programmer to maintain complete control. Controller information, such as run/stop, connection status and device information, can also be transferred to a cloud solution via cloud connectivity or distributed by an MQTT broker.

### Interfaces

With a wide variety of interfaces, WAGO’s controllers also provide the perfect foundation for an IoT gateway. They can collect numerous field signals, communicate in many industrial protocols and even enable cloud connection of sensors and actuators that have no Web interface themselves. Thanks to the standardized MQTT protocol, it is possible to connect to cloud providers such as Microsoft Azure, Amazon Web Services, IBM Cloud and SAP Cloud. Of course, other MQTT brokers or solutions like WAGO Cloud can also be connected.

### WAGO Cloud

Our WAGO Cloud offers a quick and easy display with ready-made dashboards. This lets very different user groups get the information that is important to them. Integrated device management and central firmware/application download directly from the cloud for maintenance optimization.

Additional information  
and tutorial



## External Suppliers

Whether for individual components like screws, or entire subassemblies like door or seat systems, external suppliers have become a regular fixture of the automotive manufacturing process. For this reason, OEMs (Original Equipment Manufacturers) make very high demands of suppliers when it comes to availability and quality of individual components or entire subassemblies. Learn more about our "Functional Safety" products on page 30. Similar to the powertrain, subassemblies like door or seat systems and shock absorbers are produced on assembly lines or in processing centers.

Here too, safe system startup and, in the event of a power supply failure, safe shutdown and return to a specified condition need to be guaranteed at all times to prevent downtime. Our WAGO power supplies (pp. 39 ff.) always provide a consistent supply voltage. Building management is also important for suppliers in order to efficiently integrate production systems and to record and visualize energy values. Besides production facilities, office buildings are also increasingly being targeted for energy conservation measures in order to make resource consumption more efficient and to reduce a company's carbon footprint (pp. 54 ff.).





**WAGO GmbH & Co. KG**

Postfach 2880 · D-32385 Minden  
Hansastraße 27 · D-32423 Minden  
[info@wago.com](mailto:info@wago.com)  
[www.wago.com](http://www.wago.com)

Headquarters	+49 (0)571/887 - 0
Sales	+49 (0)571/ 887 - 44 222
Orders	+49 (0)571/ 887 - 44 333



WAGO is a registered trademark of WAGO Verwaltungsgesellschaft mbH.

“Copyright – WAGO GmbH & Co. KG – All rights reserved. The content and structure of the WAGO websites, catalogs, videos and other WAGO media are subject to copyright. Distribution or modification of the contents of these pages and videos is prohibited. Furthermore, the content may not be copied or made available to third parties for commercial purposes. Also subject to copyright are the images and videos that were made available to WAGO GmbH & Co. KG by third parties.”